

Stop Devices (SE) / P-Positions

without ASI

STEIN Workpiece Transport System (STEIN 300)

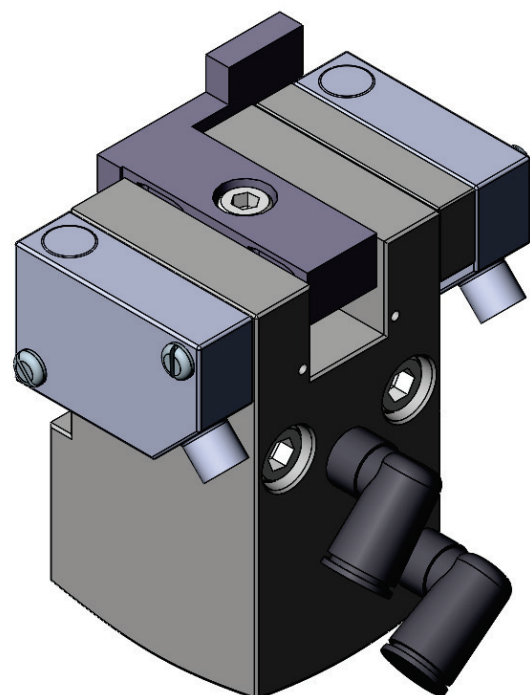
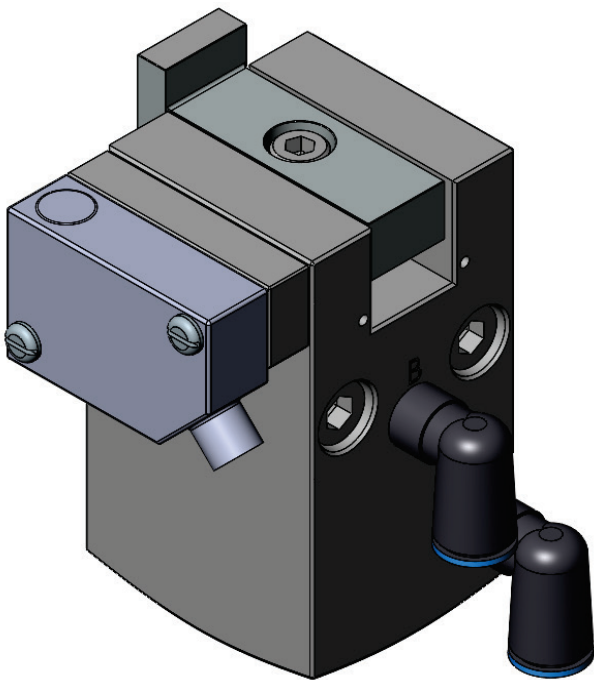

Table of contents

1	Installation, commissioning, maintenance	3
1.1	Intended use and exclusion of liability	3
1.2	Application example: 90° corner transfer.....	4
1.3	Schematic diagram and main dimensions.....	4
1.4	Mounting and connection.....	5
1.5	Startup.....	7
1.6	Faults.....	7
1.7	Accessories - proximity switch	8
2	P-Positions.....	8
2.1	Abbreviations.....	8
2.2	P01 - or P03-Accessory - 300 153 001.....	9
2.3	P02 - or P04-Accessory - 300 154 001.....	10
2.4	P05 - or P07-Accessory - 300 155 001.....	11
2.5	P06 - or P08-Accessory - 300 156 001.....	12
2.6	P09 - or P10-Accessory - 300 157 001.....	13
2.7	P11 - or P12-Accessory - 300 158 001.....	14
2.8	P13 - or P15-Accessory - 300 159 001.....	15
2.9	P14 - or P16-Accessory - 300 160 001.....	16
2.10	P21 - or P23-Accessory - 300 161 001.....	17
2.11	P22 - or P24-Accessory - 300 162 001.....	18
2.12	P25 - or P27-Accessory - 300 163 001.....	19
2.13	P26 - or P28-Accessory - 300 164 001.....	20
2.14	P29 - or P31-Accessory - 300 165 001.....	21
2.15	P30 - or P32-Accessory - 300 166 001.....	22
2.16	P33 - or P35-Accessory - 300 401 001.....	23
2.17	P34 - or P36-Accessory - 300 402 001.....	24
2.18	P37 - or P38-Accessory RB180° - 300 403 001	25
2.19	P39 - or P40-Accessory RB90° - 300 404 001.....	26
2.20	P41 - or P42-Accessory 2xRB90° - 300 405 001.....	27
2.21	P43 - or P44-Accessory 2xRB180° (Alpha) - 300 406 001.....	28
3	Installation Declaration	29

1 Installation, commissioning, maintenance

Installation, operating and maintenance personnel - keep on hand for further use!



DANGER!

The stop devices are designed for installation in other capital goods - for example, automation or assembly systems. The manufacturer of the systems is obligated to install the stop devices in accordance with the applicable regulations of the Machinery Directive, and the applicable accident prevention regulations.

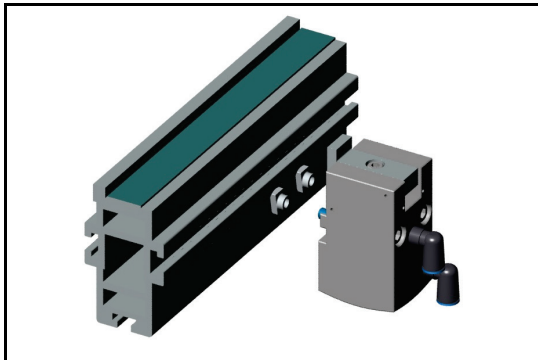

Function of the stop devices:

The function of the stop devices is to separate and position the pallets at STEIN corner transfer units or radius circuits, at inward and outward transfers and at workstations.

Types of stop devices:

- Stoppers
- Stoppers with centring rails

The stop devices from STEIN Automation are high-quality products, manufactured to recognized technical rules. The devices leave the manufacturing plant in faultless condition! To maintain this situation, installers, users and service technicians must comply with the the instruction and warnings contained in this description!

The devices should only be used for the purpose for which they have been designed and in compliance with the specifications cited in this description.

STEIN Automation accepts no liability for any damage caused by unauthorised interventions, alterations or repairs. Only original spare parts from STEIN Automation may be used when carrying out repairs to the devices.

Type plate:



1.1 Intended use and exclusion of liability

The stop devices should only

- be installed as independent components or
- be built into STEIN 300 belt systems.
Compatibility is only assured with STEIN 300 belt modules.
- be operated indoors,
- be operated in dry areas,
- be used in areas where there is no risk of explosion.
- be operated in an environment that is free of oil and shavings.

1.2 Application example: 90° corner transfer

- 1 Pre-stopper (VS) with attached proximity switch (NS)
- 2 Outer switch (SA)
- 3 Transfer unit 90° (U 90)
- 4 Switch down (SU)

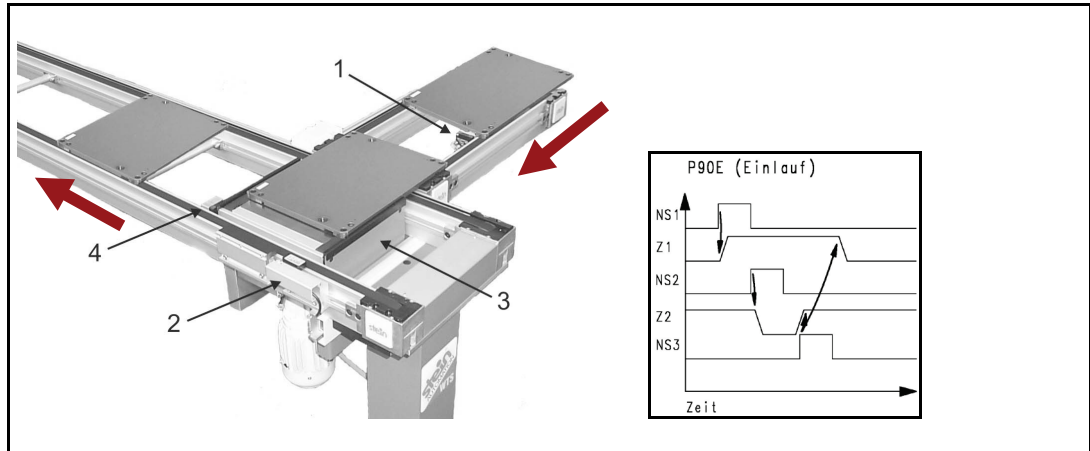



Electro-pneumatic process - basic position: Pre-stopper latch down, transfer unit up.

- **1 VS (Z1, NS1)** - the proximity switch NS1 receives a signal from the WT stop plate that activates the cylinder of the pre-stopper Z1
→ "Stopper stop up" so the following WT is held back.
- **2 SA (NS2)** - the proximity switch NS2 receives a signal as soon as the WT is completely over the transfer unit, which activates the cylinder of the transfer unit.
- **3 U90 (Z2)** "Transfer unit down".
- **4 SU (NS3)** - the proximity switch NS3 receives a signal as soon as the WT has left the transfer area, which de-activates all the stop situation cylinders
→ pre-stopper stop down (next WT can enter the transfer area) transfer unit up.

1.3 Schematic diagram and main dimensions

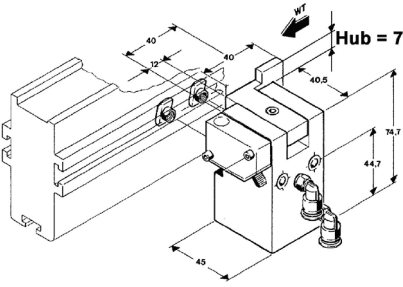
Stopper (S) 300 006 001	Pre-stopper (VS) - 300 007 001	Workstation pre-stopper (AS) - 300 009 001
Entry side stopper with right-angled catch (ES) - 300 008 001	Workstation stopper with right-angled catch (ASA) - 300 112 001	Workstation stopping device with right-angled stop (ASB) - 300 168 001

Workstation stopping device with right-angled stop (ASC)	Technical data – 300 169 001	
	<ul style="list-style-type: none"> • Cylinder diameter • Operating pressure • Air consumption per double lift • Lift 	<ul style="list-style-type: none"> • 32 mm • 7 mm • 4 bar • 0.04 / double lift
		Planning data is provided on the Internet

1.4 Mounting and connection



CAUTION!

Only specialized personnel should connect the device to the compressed air supply!



CAUTION!

Before carrying out any installation or repair work, disconnect the higher-level system or machine from the power supply and compressed air supply.

Perform tasks on stop devices

- in accordance with the descriptions in this documentation,
- in compliance with relevant safety and accident prevention regulations and
- in a technically correct manner and with the greatest possible accuracy.



General instructions for installing the stop devices are provided below. Installation of the stoppers for your particular application can vary from these instructions.

The stopper and the centring rails are mounted directly inside on the belt profile of the belt element. On STEIN WTS systems stopper installation does not require any change to the belt elements! Installation is organised in

- installation of the stoppers/the centring rails/ the stops and sensors and
- connection of the electrical and pneumatic components to the mains supply and the compressed air network.

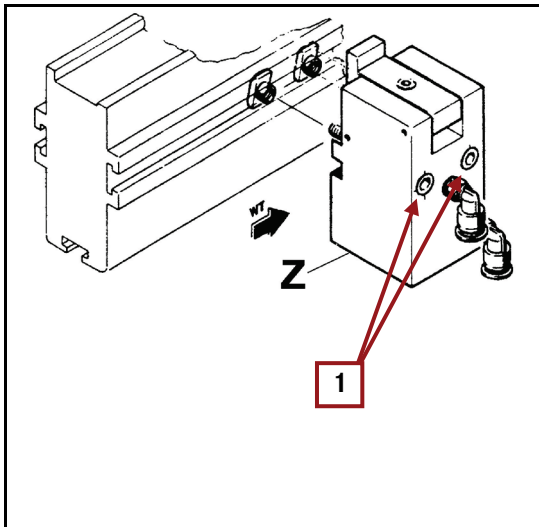

Stoppers

The stoppers are mounted on the inside of the belt elements on the guide profile. Sliding blocks can be used for mounting for systems with profile grooves.

To change the position of previously installed stoppers, unscrew the two fixing screws (1) with a wrench.

Turn each of the screws one full turn counterclockwise with the wrench. This ensures the required twisting of the groove nuts when tightening the stopper. When the stopper is in the right position, tighten both screws (clockwise). In this process ensure that the groove nuts twist correctly.

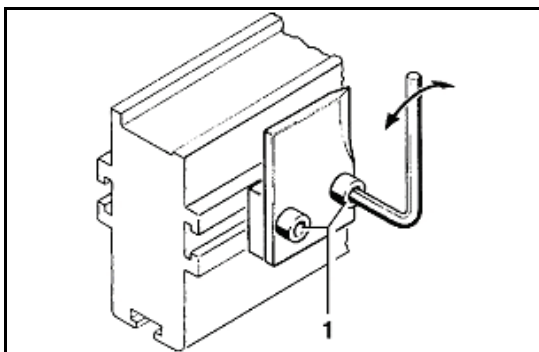

Centring rails

The centring rails are also mounted on the inside of the belt element.

The position of the rails depends on the position of the stoppers and the dimensions of the WT.

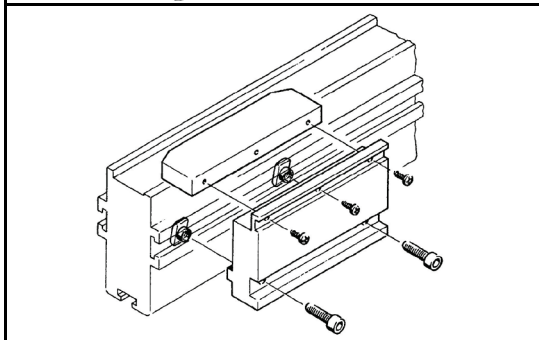

Mechanical stop

The stops are also mounted on the inside of the belt elements via profile grooves.

The position of the rails depends on the position of the stoppers and the dimensions of the WT.



ATTENTION!

For machining stations that generate shavings (for example drilling or thread-cutting machines), covers should be installed to prevent shavings or coolant from getting into the belt element or the stop device!



ATTENTION!

Lay out the cables and lines in such a manner that they do not obstruct the system processes, and so that kinks, crushing, or scoring are prevented!



Contact us if any problems or questions come up with the installation
+49-(0)7720-8307-0.

1.5 Startup



ATTENTION!

After installation of a stop device and before starting up a system, check the following:

- Ensure that all the electric and pneumatic leads and hoses are correctly connected
- Ensure that all mechanical components have been securely bolted
- Ensure that all tools and other equipment have been cleared from the transport area
- Ensure that all safety equipment, such as protective grilles, emergency stop buttons and similar items, are properly installed and fully functional.
- Then execute a trial run and ensure that the stop devices function properly and safely.

1.6 Faults



ATTENTION!

If faults, malfunctions or safety-related damage should to the stop devices should occur, the higher-level system must be taken out of service immediately.

The causes must be determined and eliminated out by qualified, trained personnel. Only release the system for use after you have carried out a successful trial run!

Fault	Cause	Correction
Stop latch does not lower	Excessive queue load	Install intermediate stopper.

Cleaning

Depending on the degree of fouling, the stopper devices or the affected parts must be cleaned at shorter or longer intervals.

- When cleaning, do not use any abrasive, corrosive or scouring cleaning fluids or cleaning agents.
- Remove dust, shavings or any other particles with a vacuum cleaner - do not use compressed air!
- Clean fouled surfaces with a soft, lint free cloth, lightly dampened with cleaning fluid.
- Prevent fluid from getting into the components of the system or of the processing stations.

1.7 Accessories - proximity switch

An inductive proximity switch is available as an accessory for scanning pallets. The proximity switch is mounted directly on the stopper or on the switch below.

Technical data	NBB5-F1-V3-Y192044	
Switching distance s_n	5 mm	
Assured switching distance s_a	0 to 4.05 mm	
Operating voltage U_B :	10 to 30 V DC	
Operating current I_L :	0 to 250 mA	
Connection:		
Pin 1: L+ 3: L- 4: Out+		

2 P-Positions

2.1 Abbreviations

300 016 001	Mechanical stopper, inside	AI
300 015 001	Mechanical stopper, outside	AA
300 009 001	Workstation stopper	AS
300 008 001	Entry side stopper	ES
300 007 001	Pre-stopper	VS
300 056 001	Switch holder	SEA
300 137 001	Surface switch	FLS
300 012 001	Switch, bottom	SU
300 013 001	Switch ext.	SA
300 055 001	Stopping device	SEAE
300 273 001	Reading head	
300 392 001	Installation set 90° corner workstation	
300 122 001	Installation set 180° corner workstation	
300 121 001	Installation set 180°	
300 120 001	Installation set 90°	

2.2 P01 - or P03-Accessory – 300 153 001

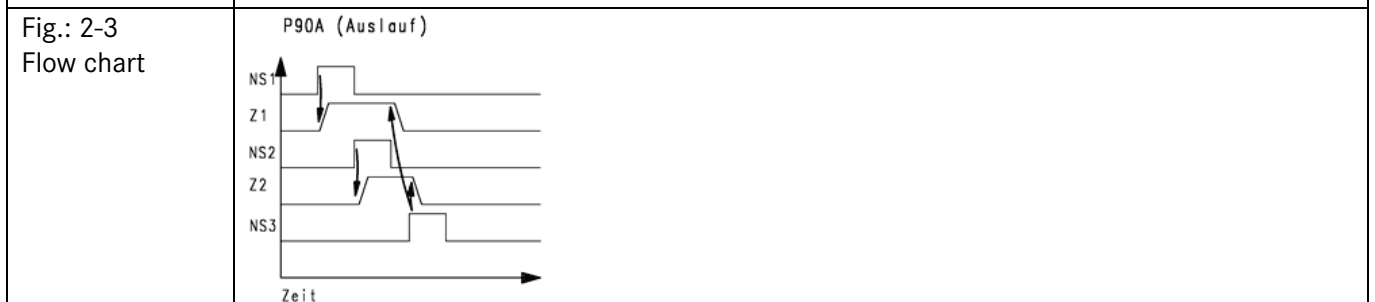
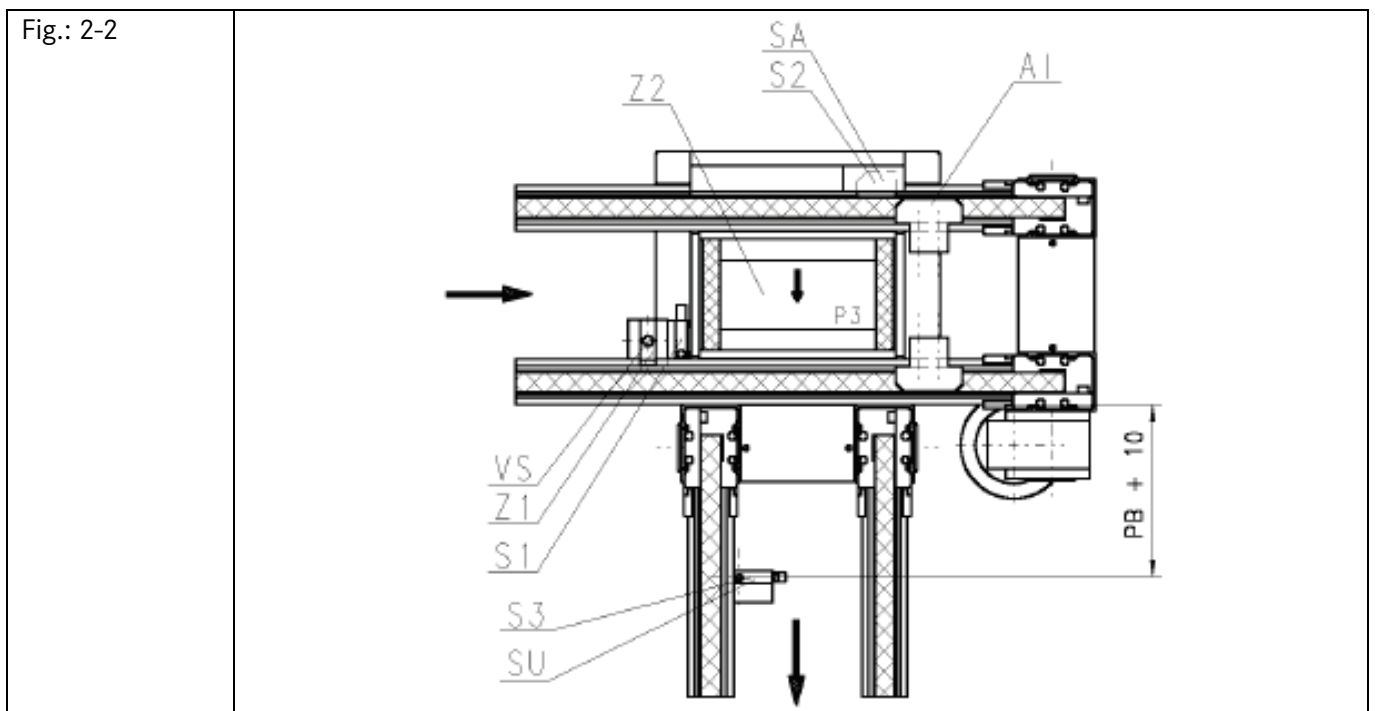
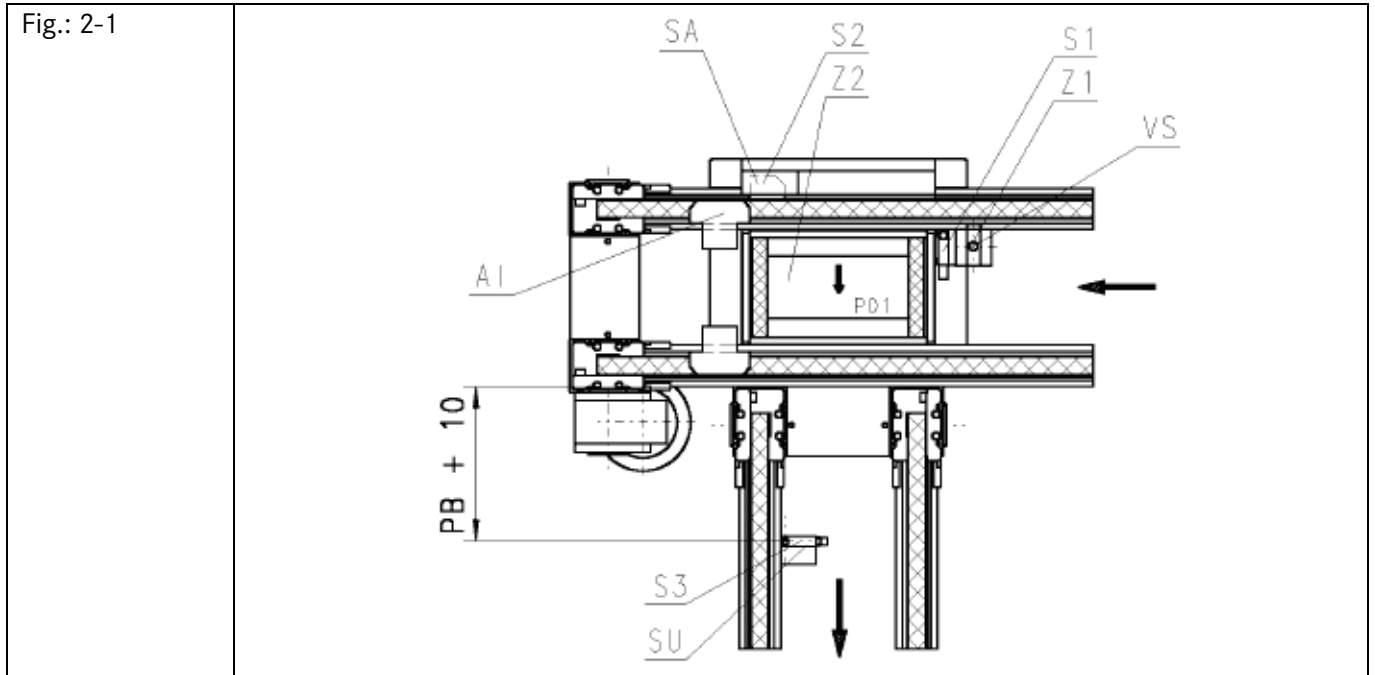

2.3 P02 - or P04-Accessory – 300 154 001

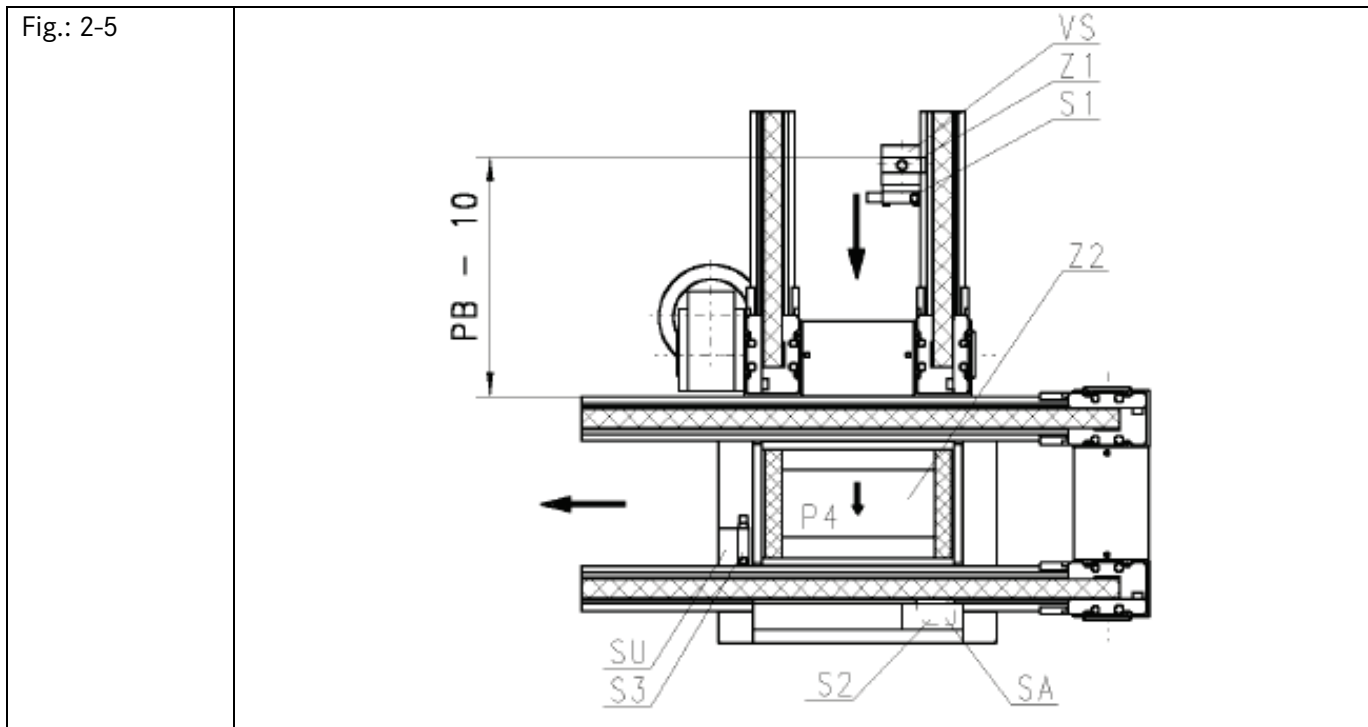
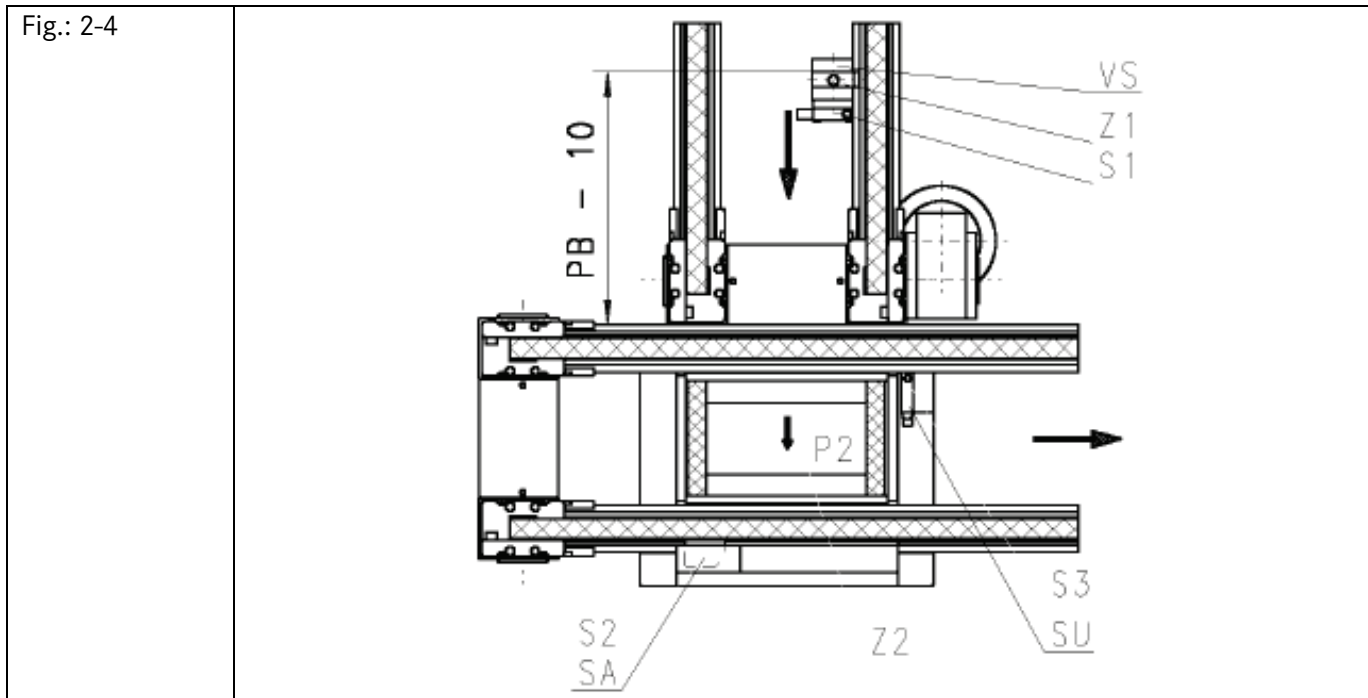

2.4 P05 - or P07-Accessory – 300 155 001

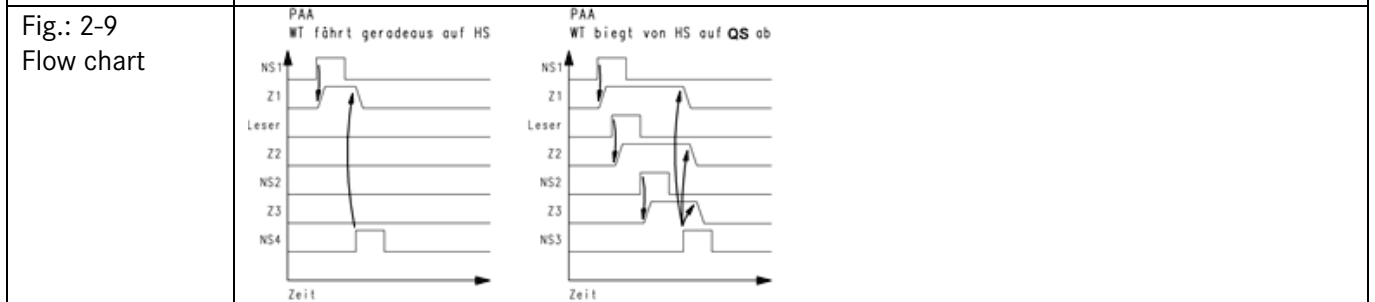
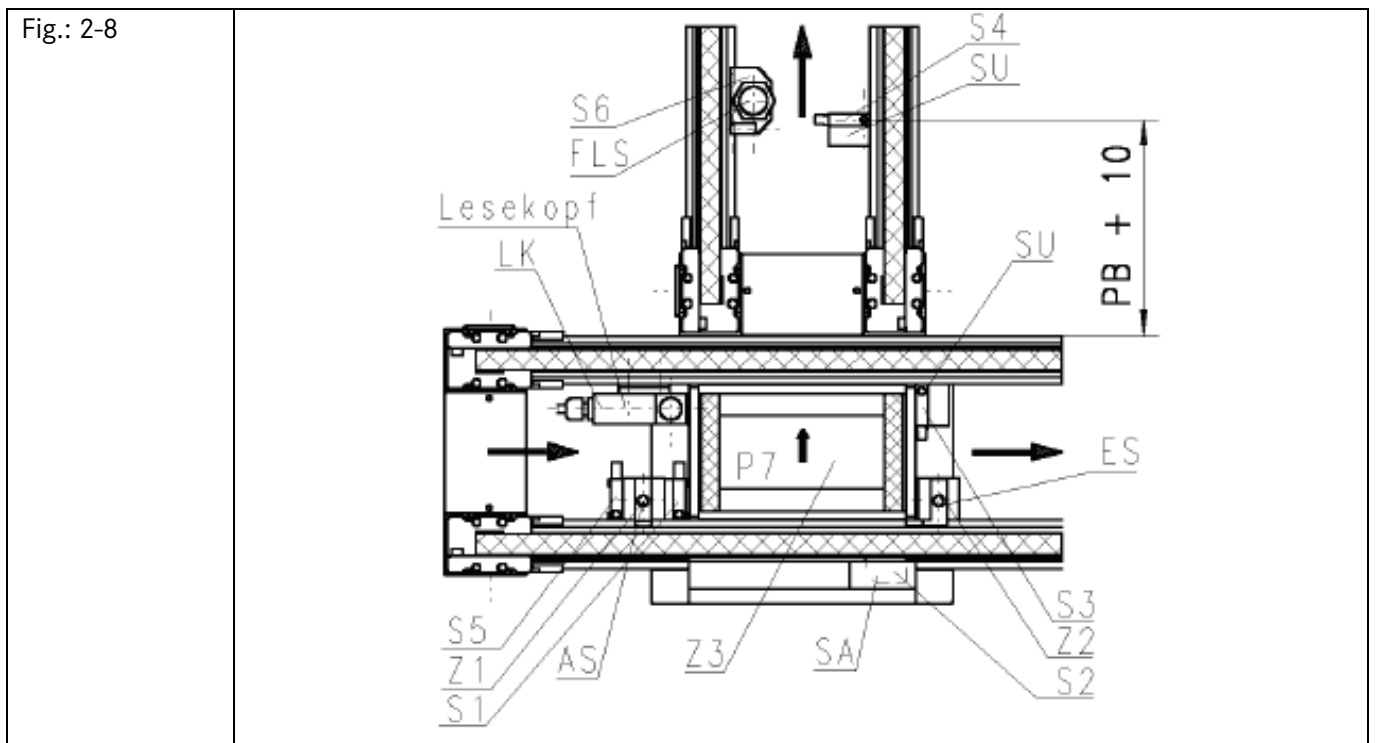
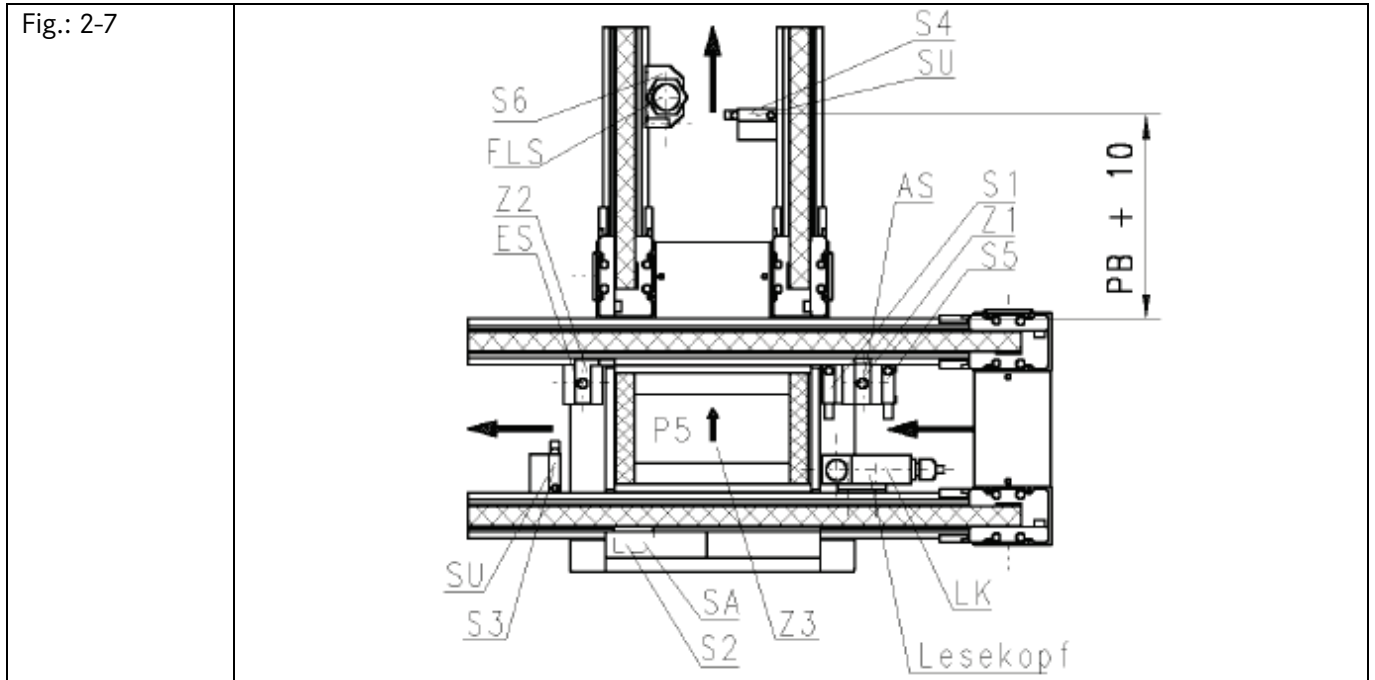

2.5 P06 - or P08-Accessory – 300 156 001

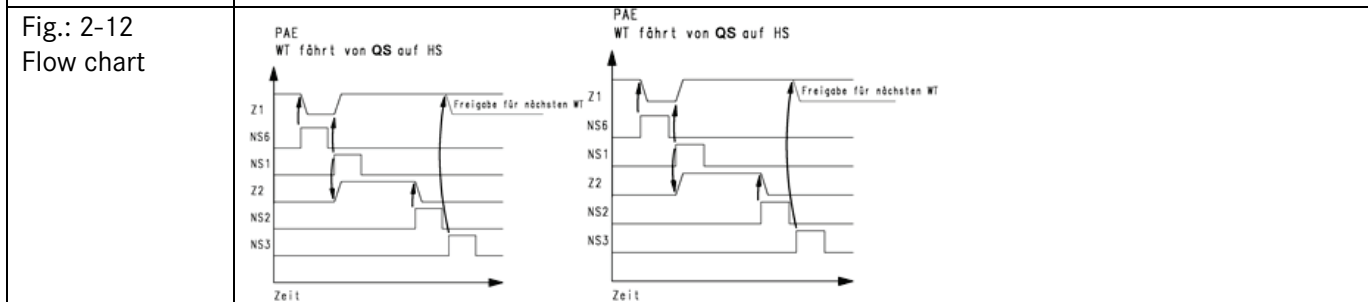
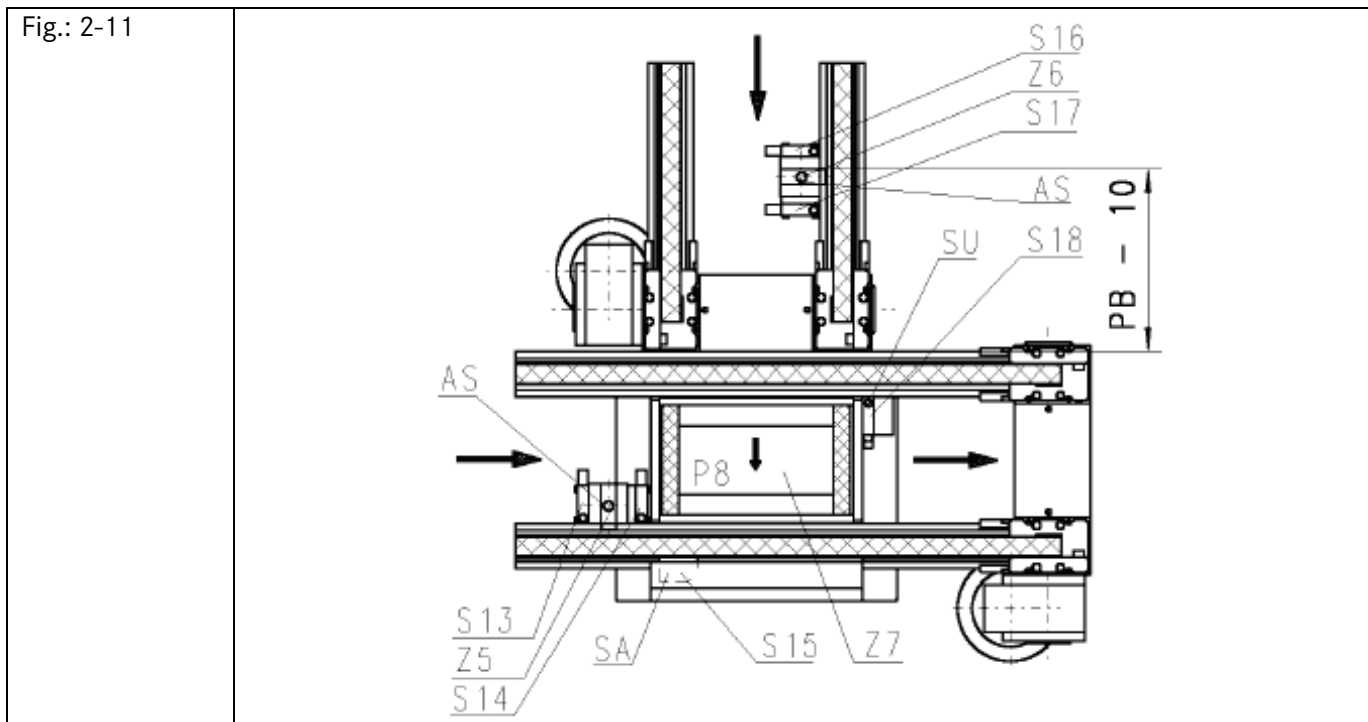
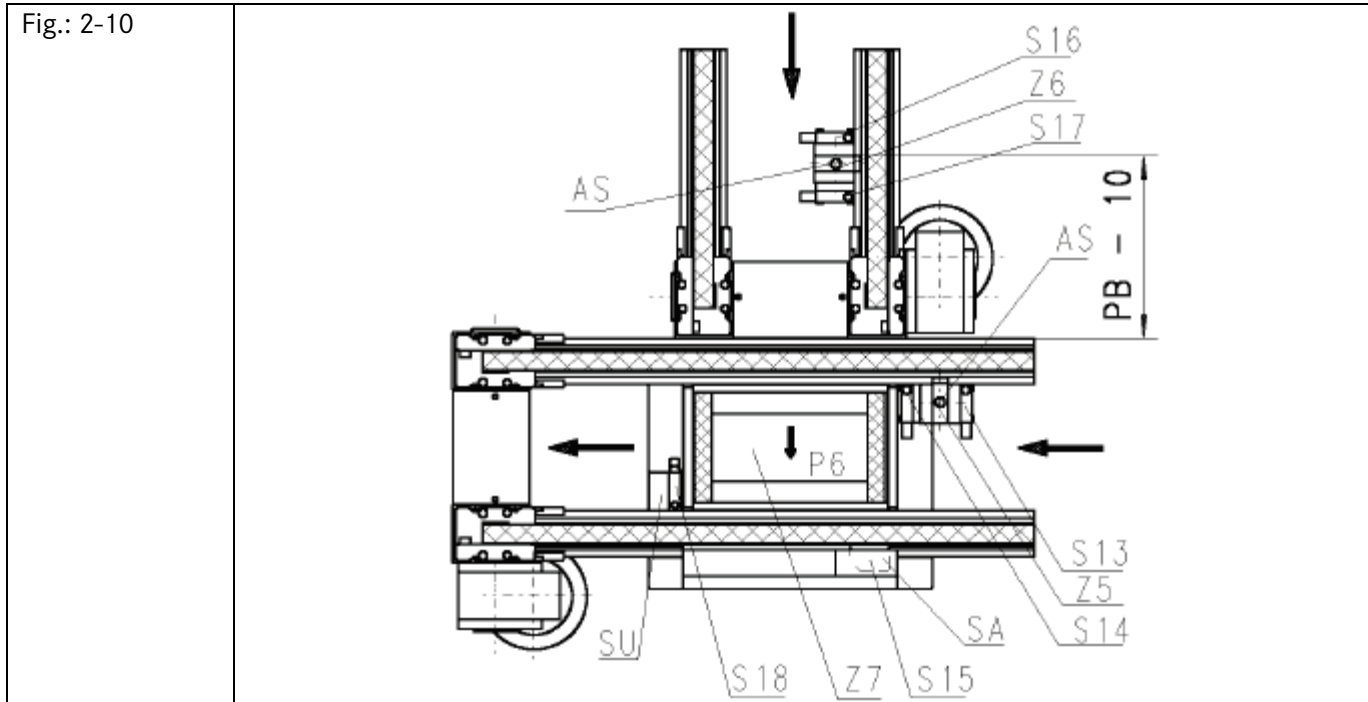

2.6 P09 - or P10-Accessory – 300 157 001

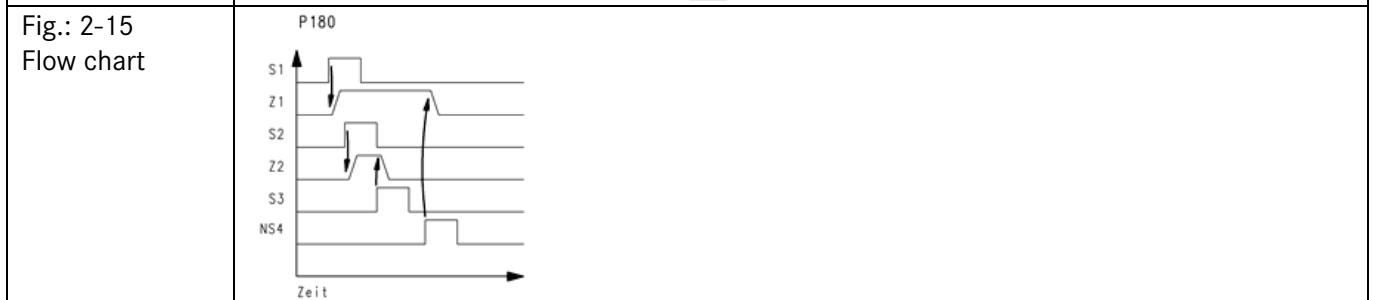
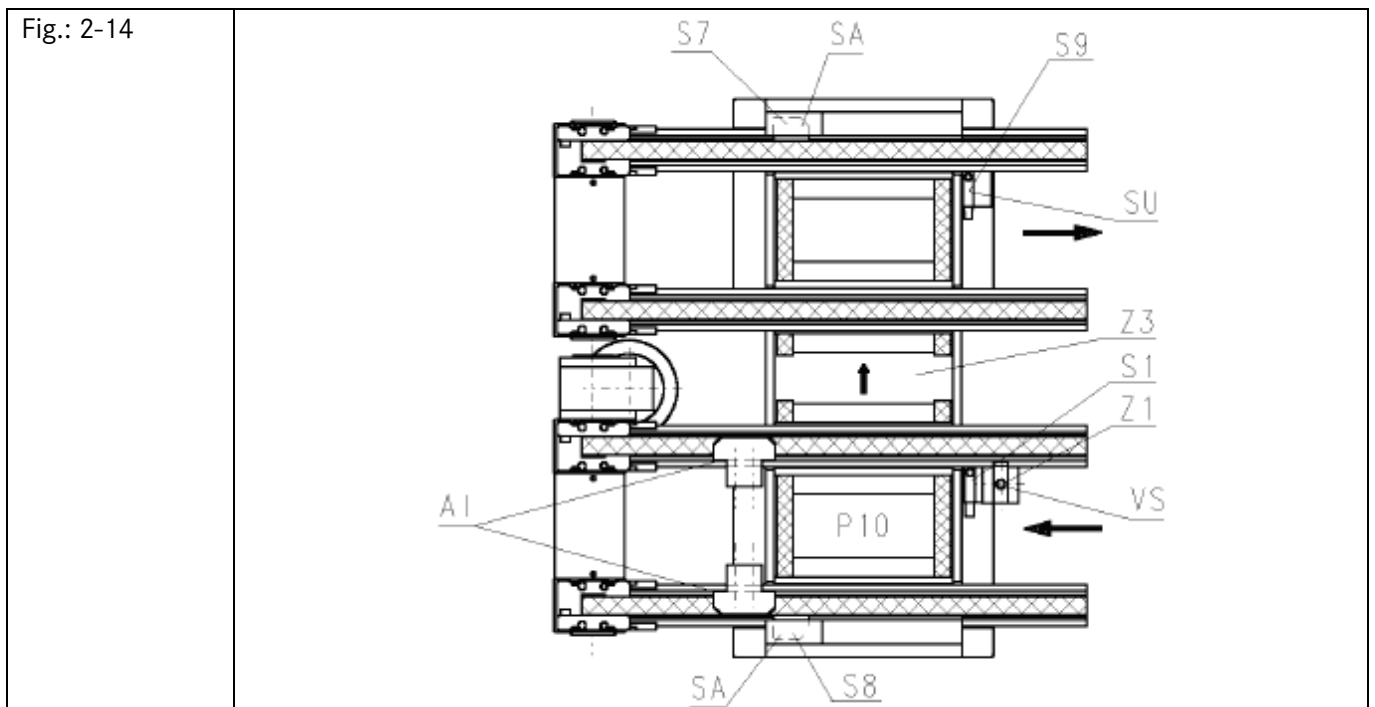
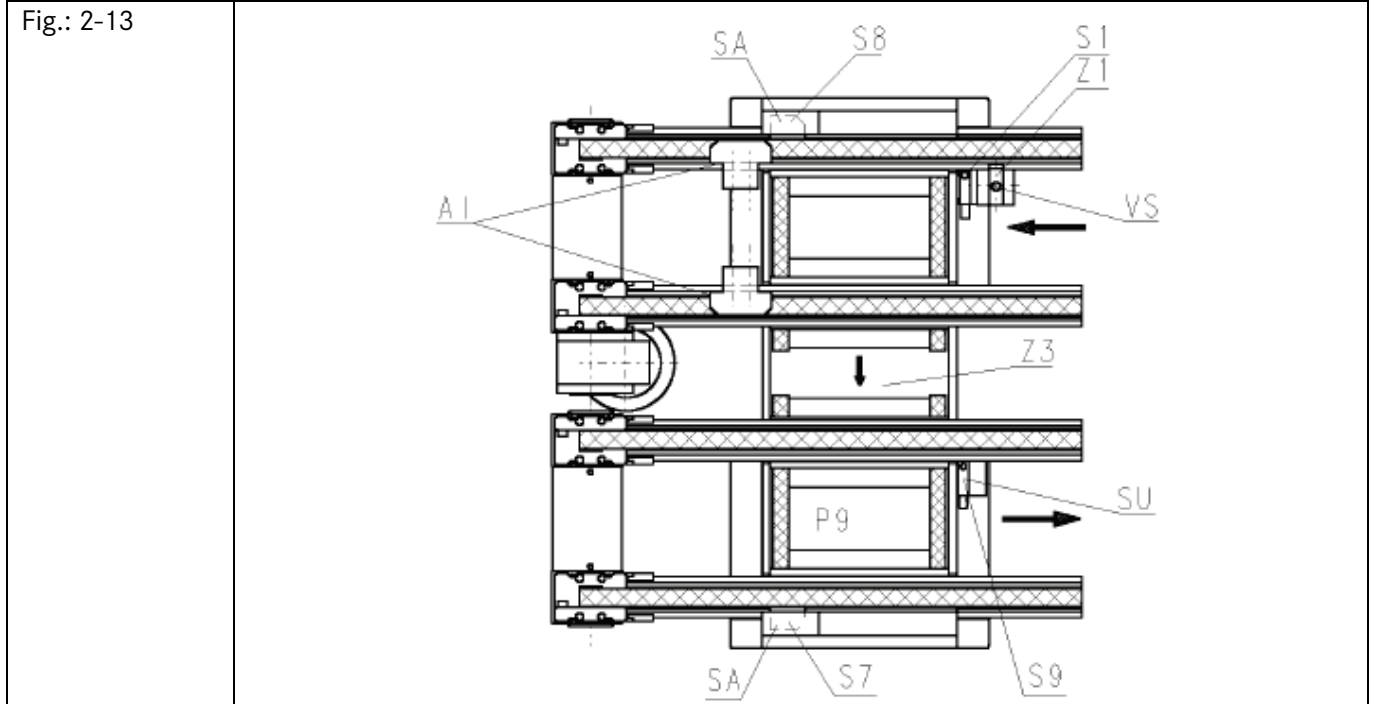

2.7 P11 - or P12-Accessory – 300 158 001

Fig.: 2-16

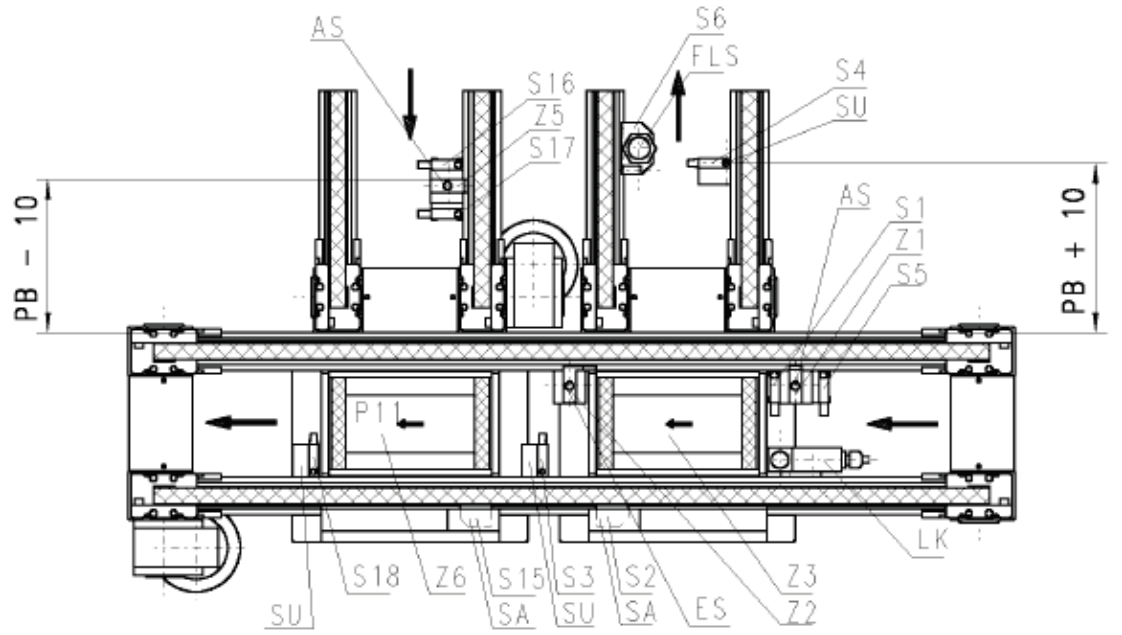

Fig.: 2-17

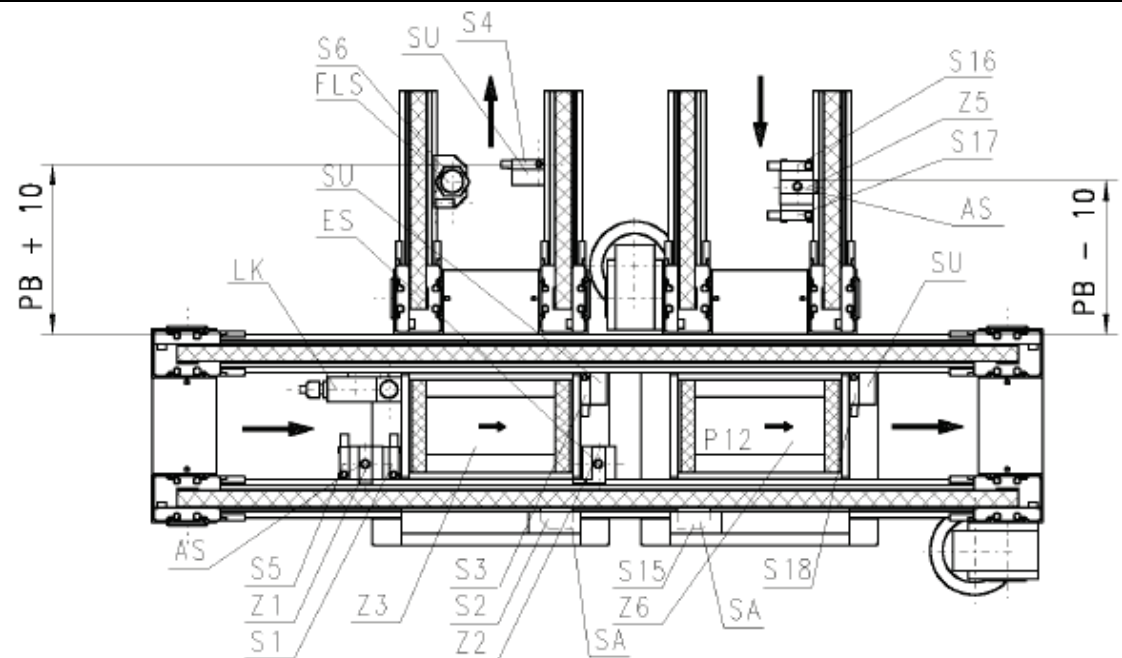
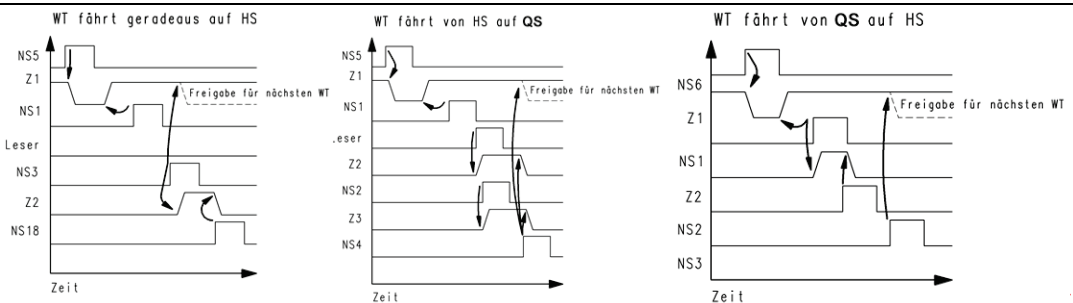
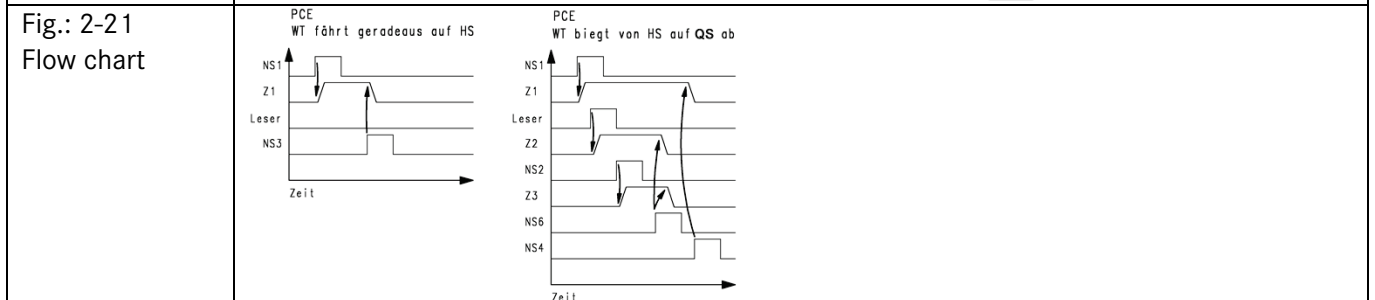
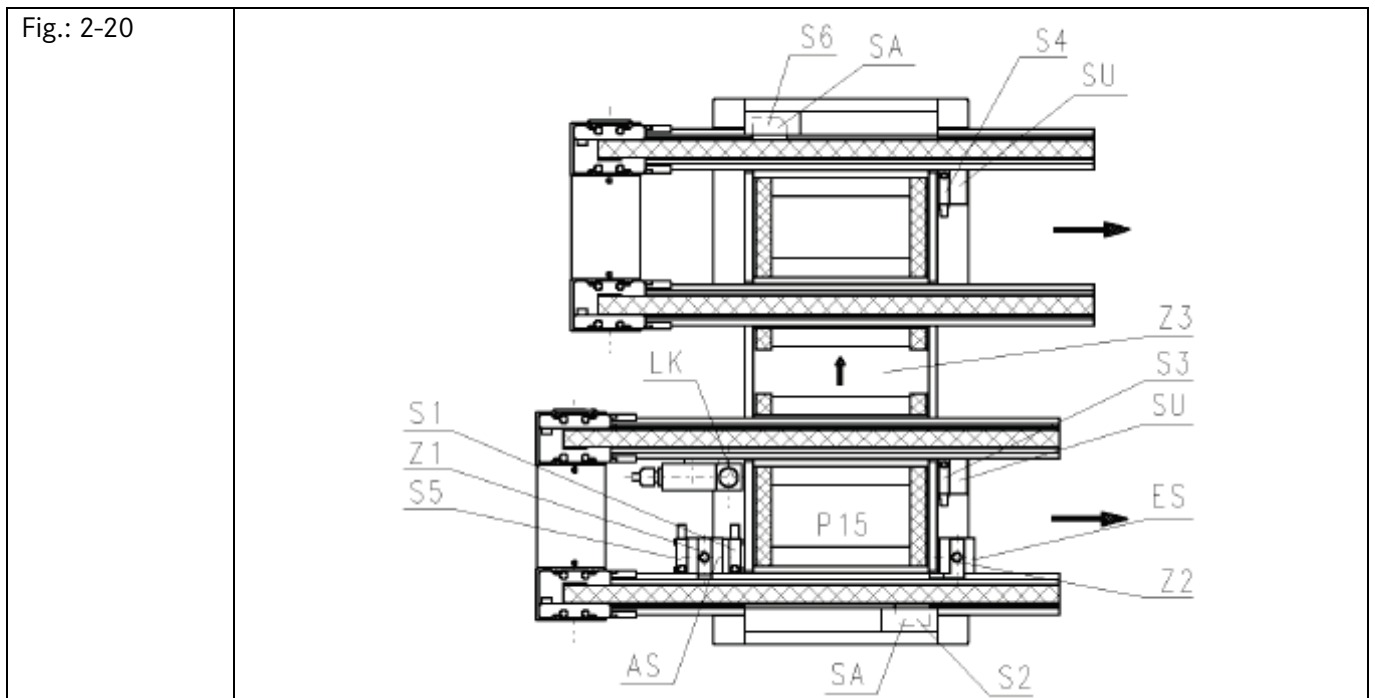
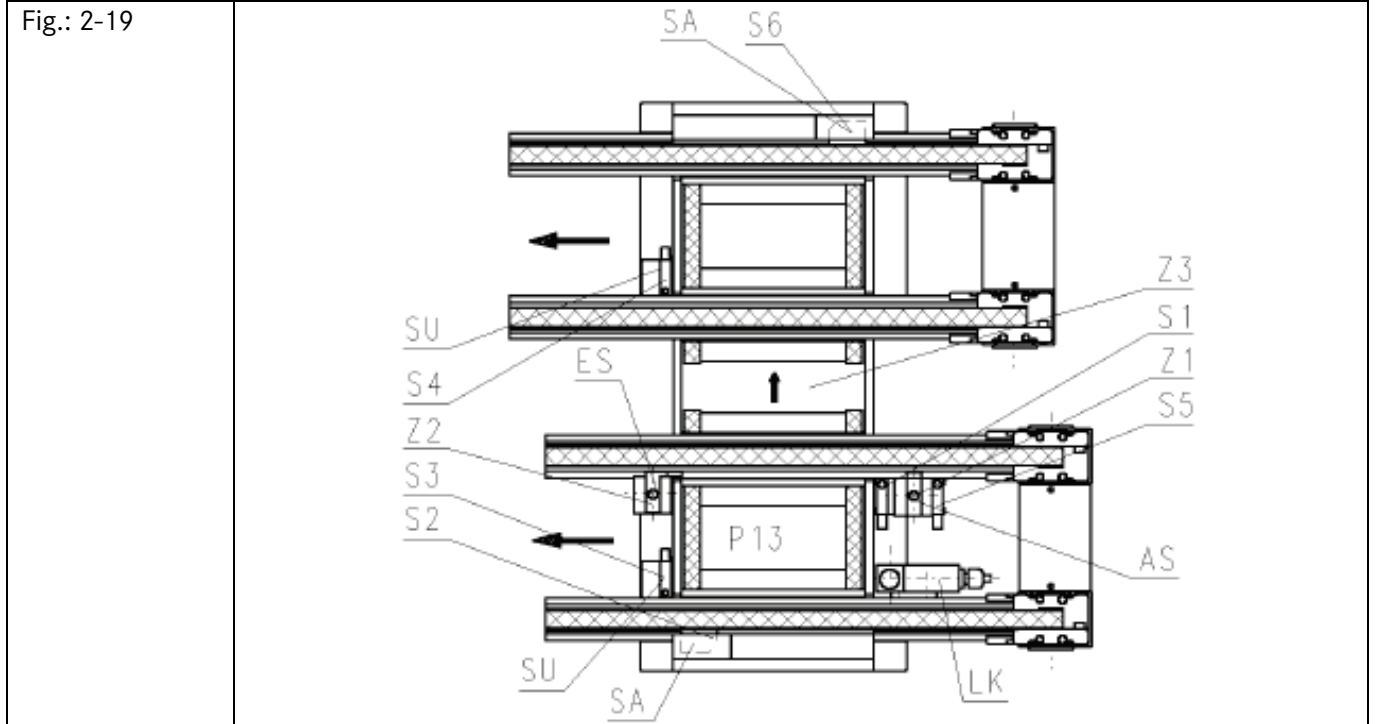

Fig.: 2-18
Flow chart



2.8 P13 - or P15-Accessory – 300 159 001



2.9 P14 - or P16-Accessory – 300 160 001

Fig.: 2-22

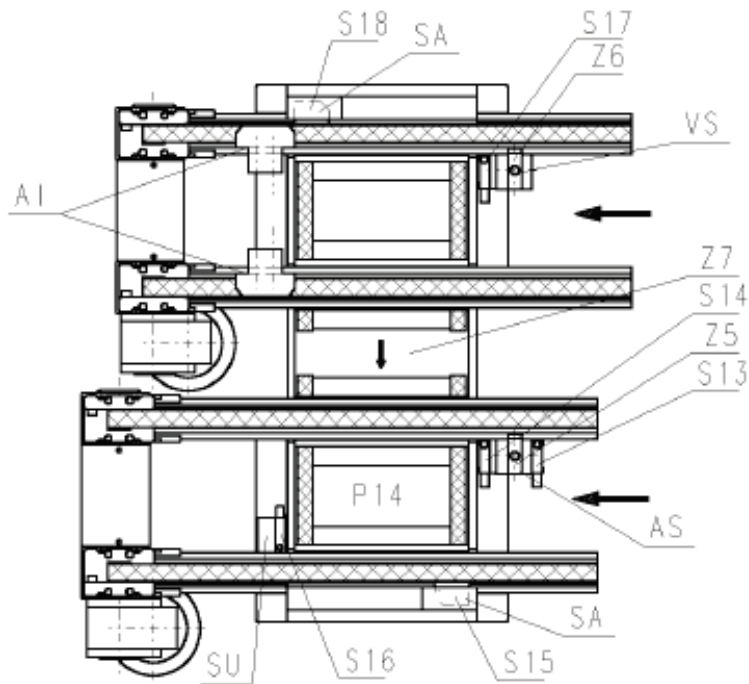

Fig.: 2-23

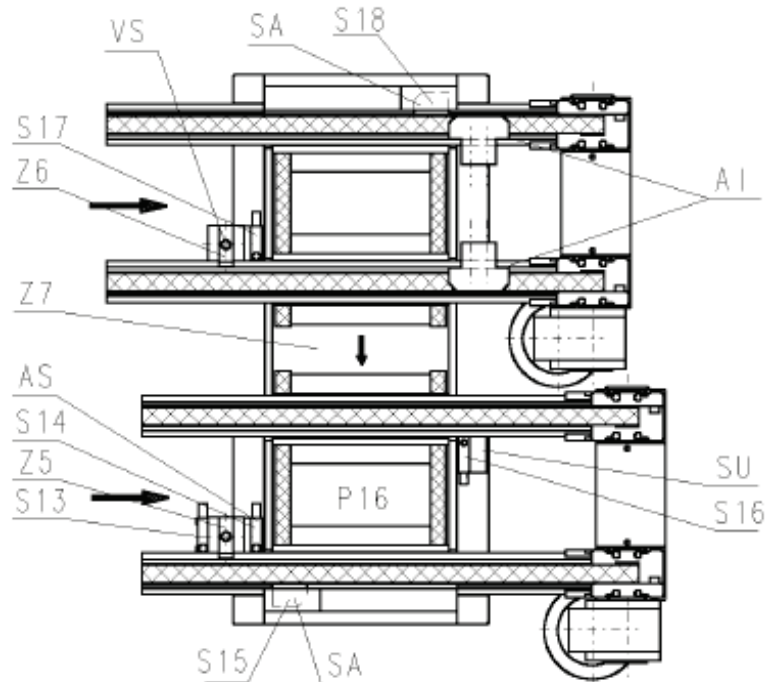
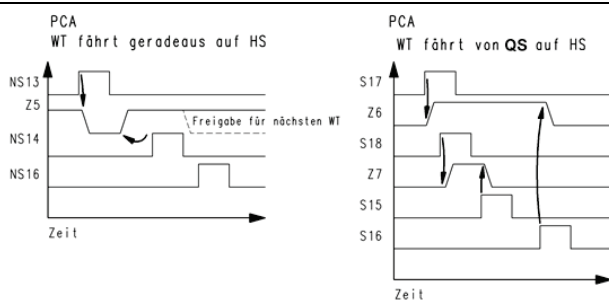
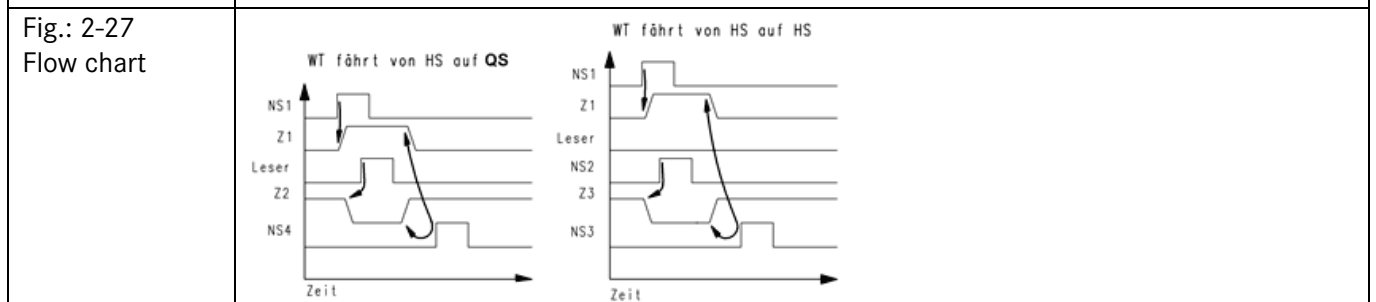
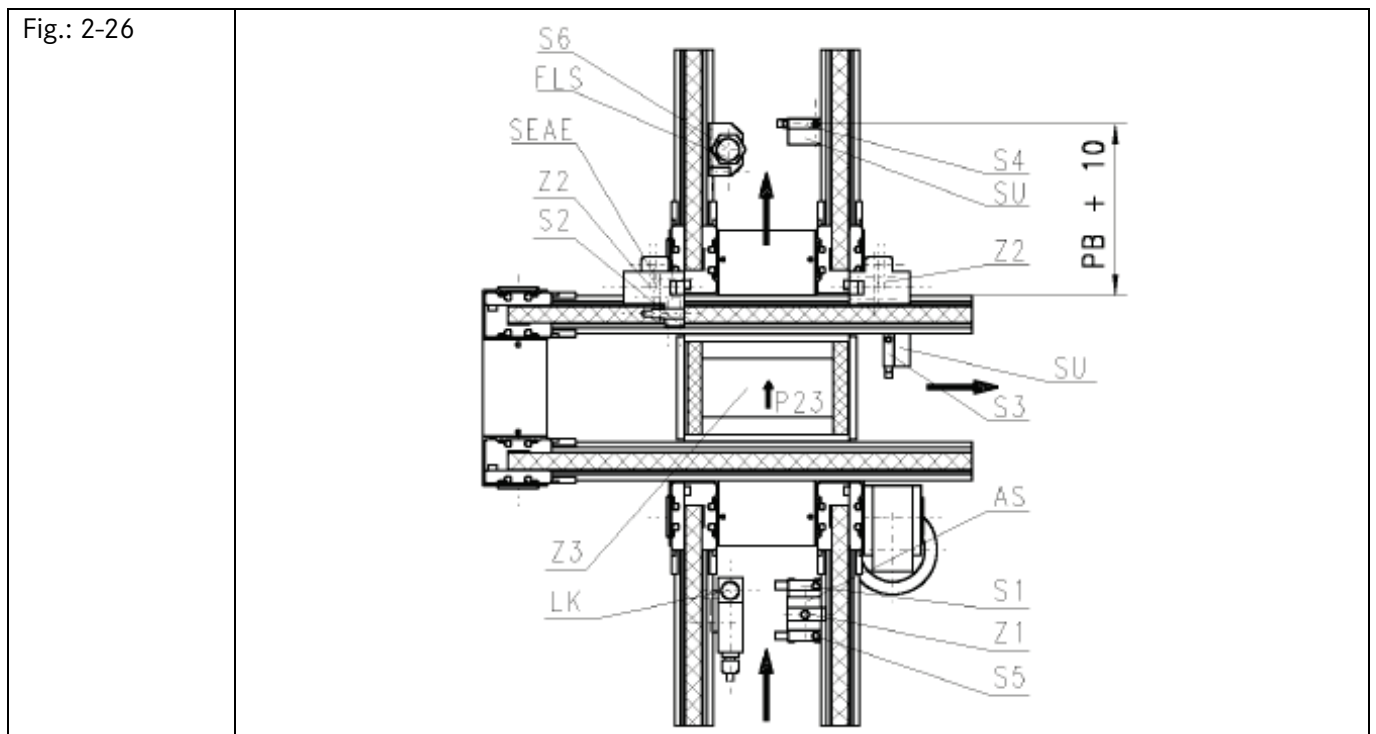
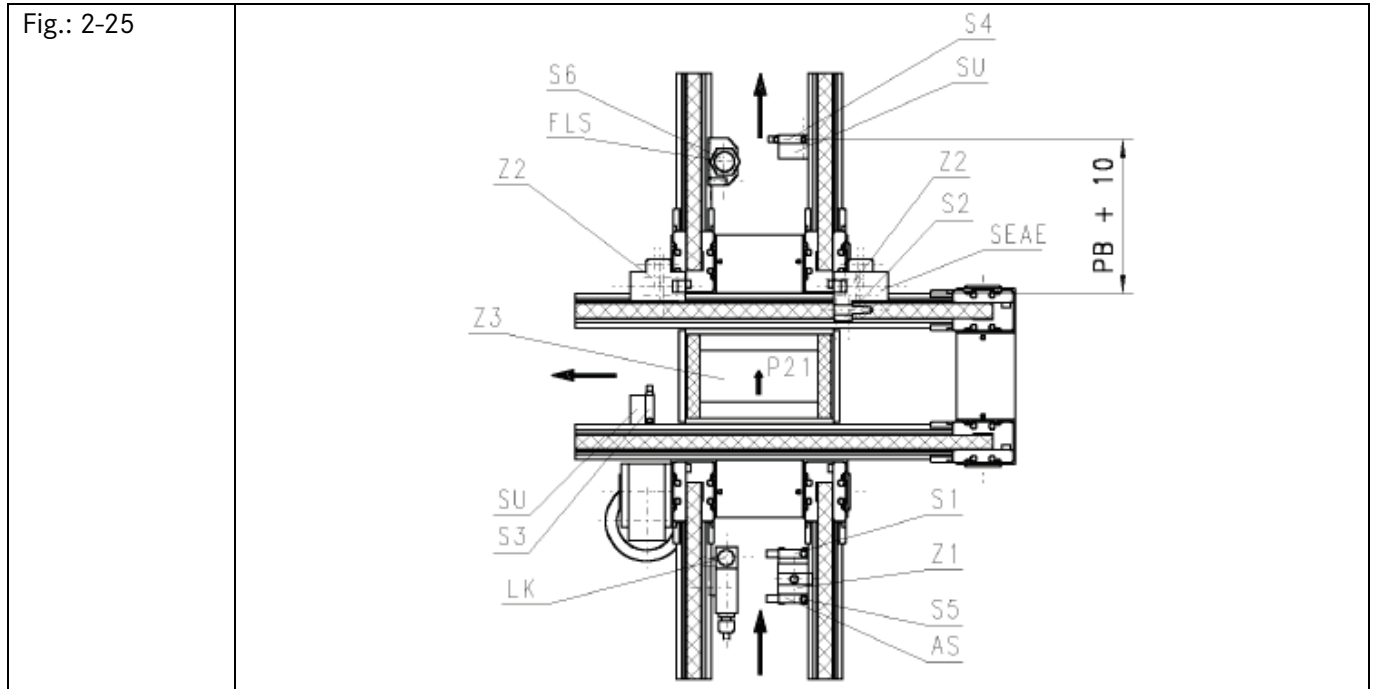

Fig.: 2-24
Flow chart



2.10 P21 - or P23-Accessory – 300 161 001



2.11 P22 - or P24-Accessory – 300 162 001

Fig.: 2-28

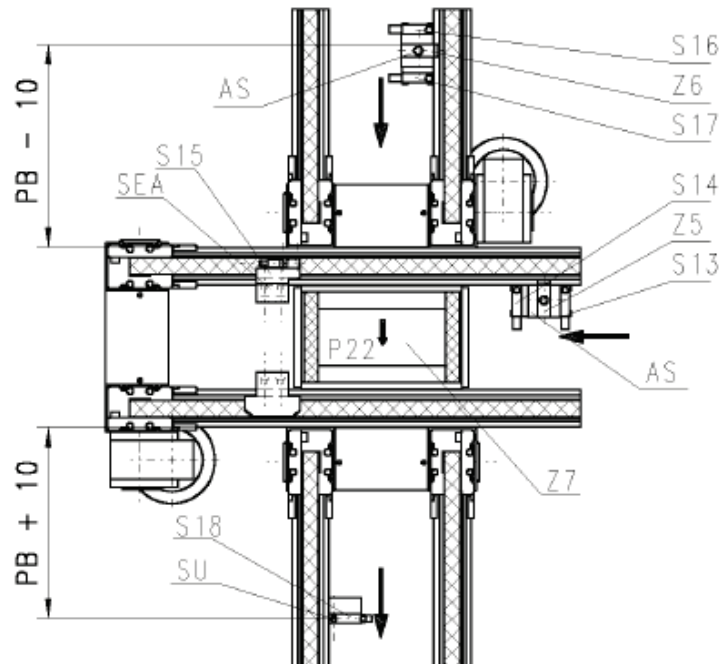

Fig.: 2-29

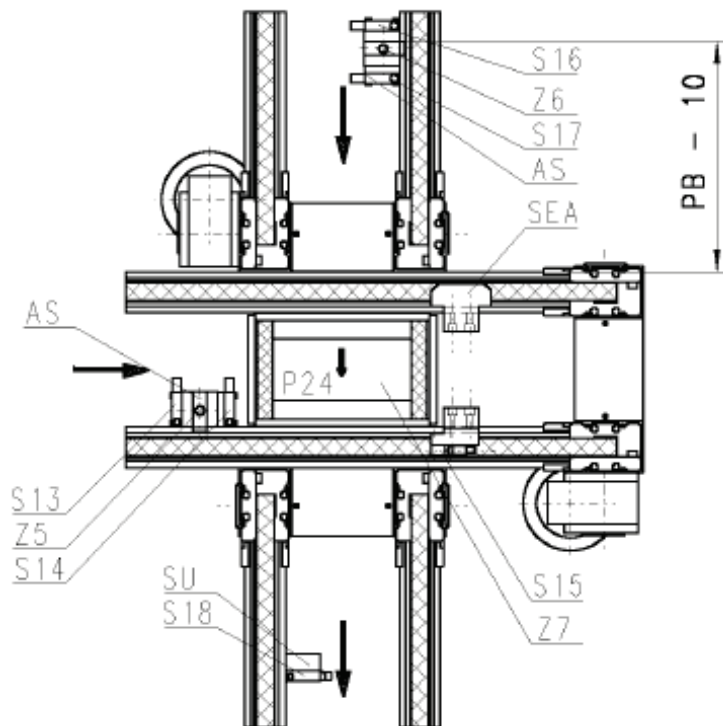
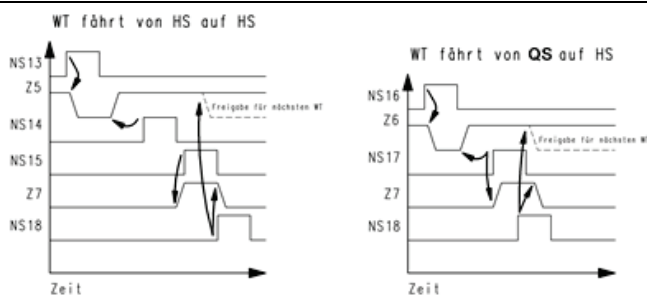
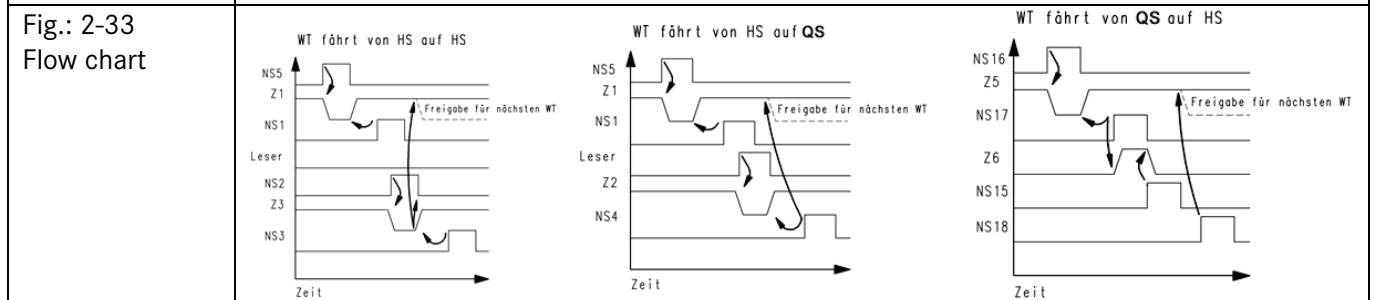
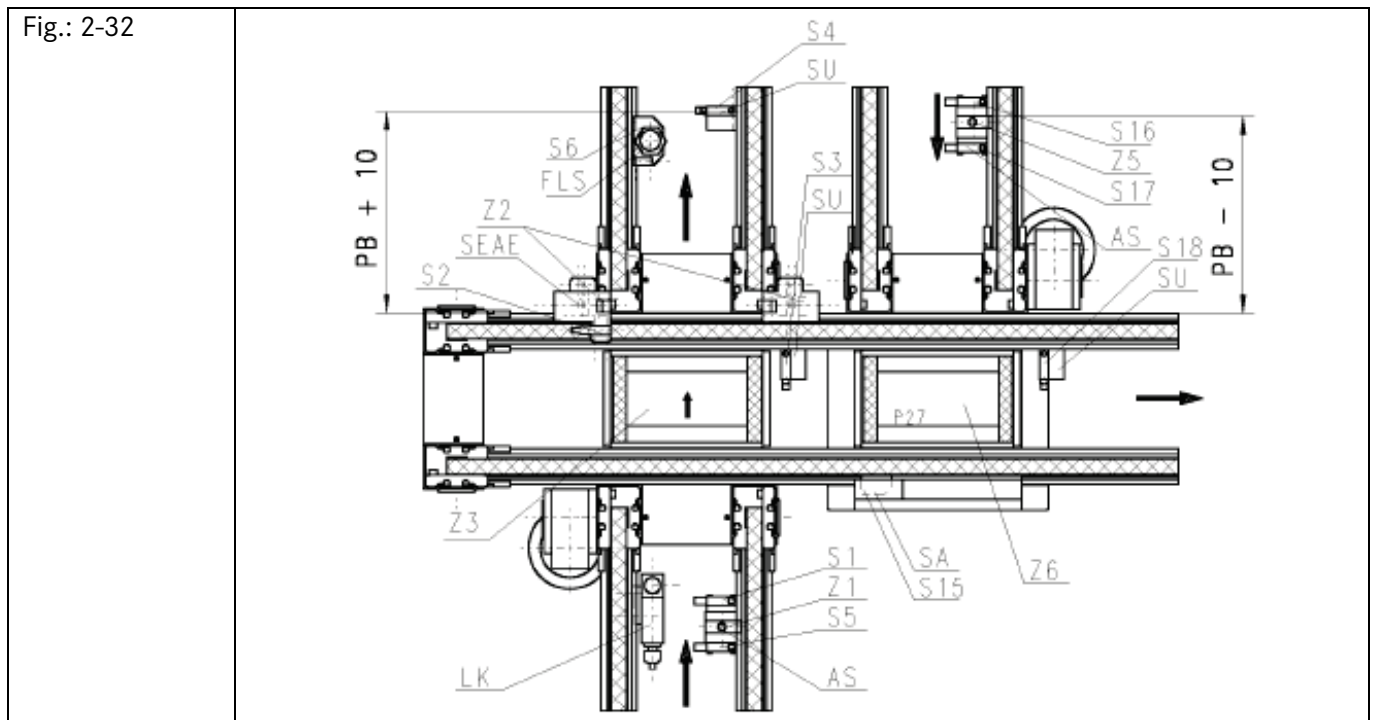
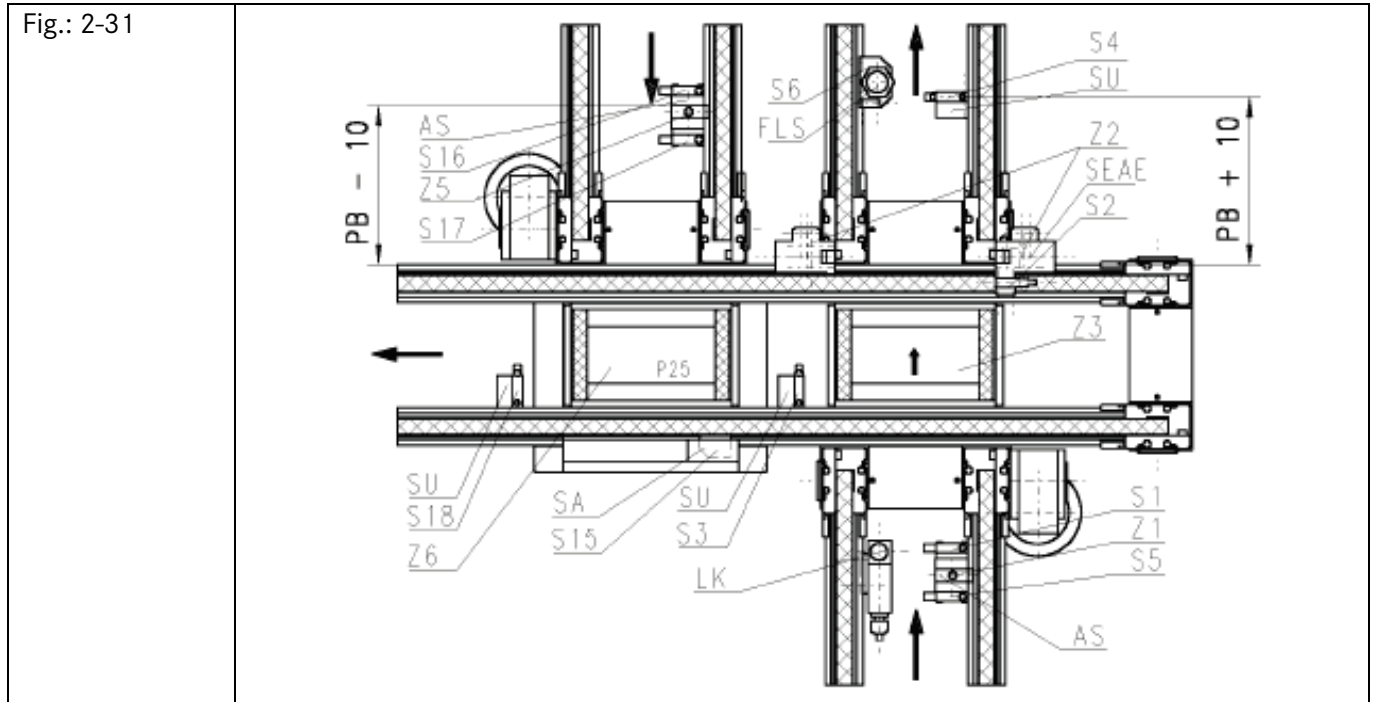

Fig.: 2-30
Flow chart



2.12 P25 - or P27-Accessory – 300 163 001



2.13 P26 - or P28-Accessory – 300 164 001

Fig.: 2-34

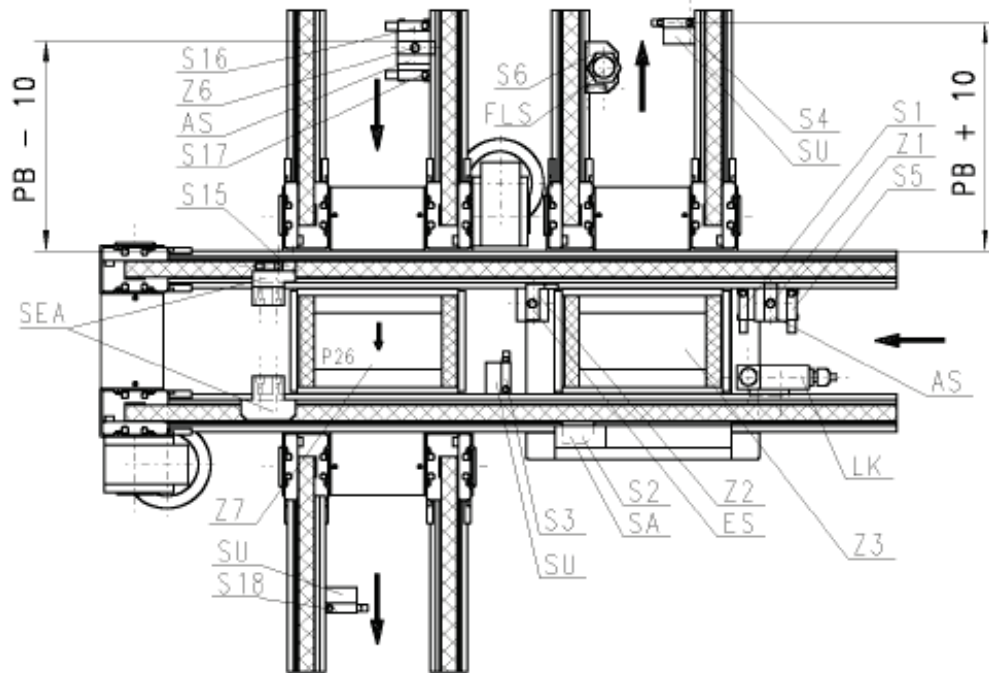

Fig.: 2-35

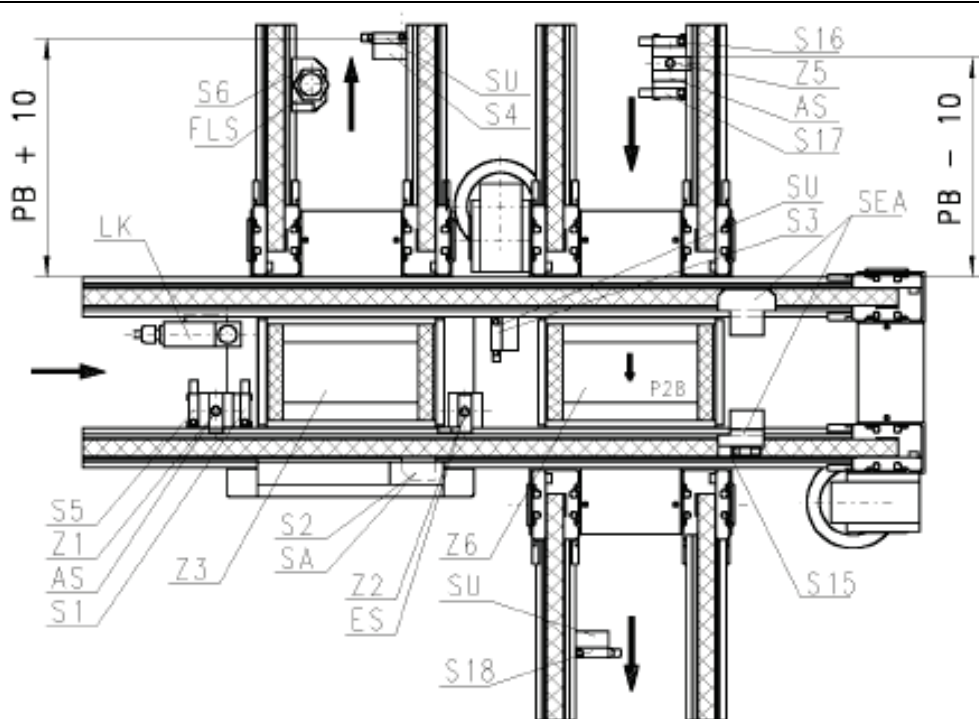
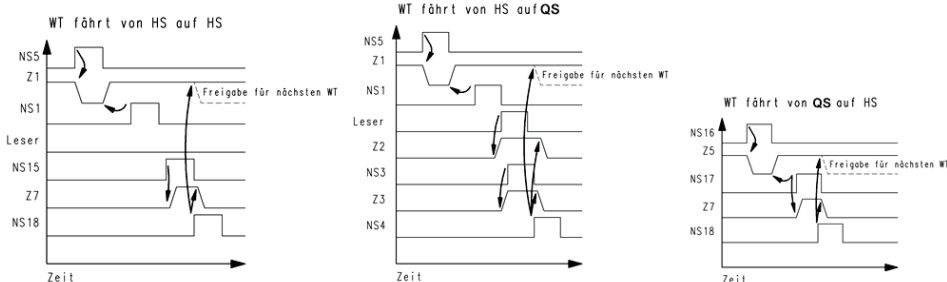
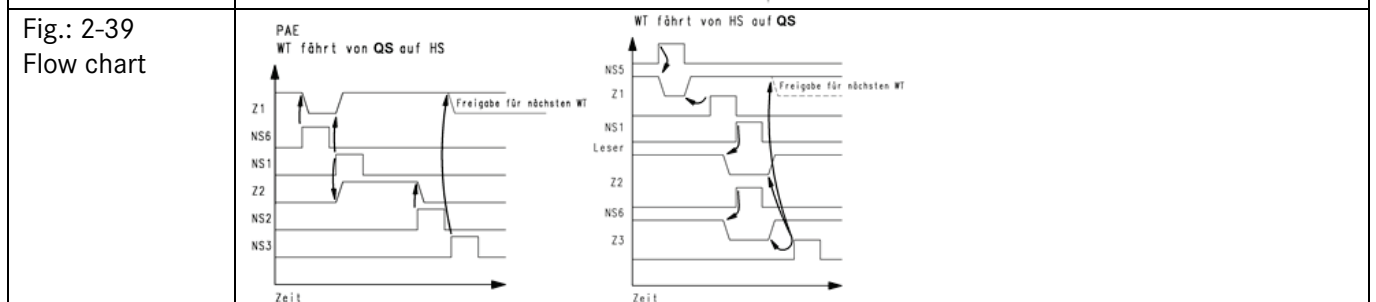
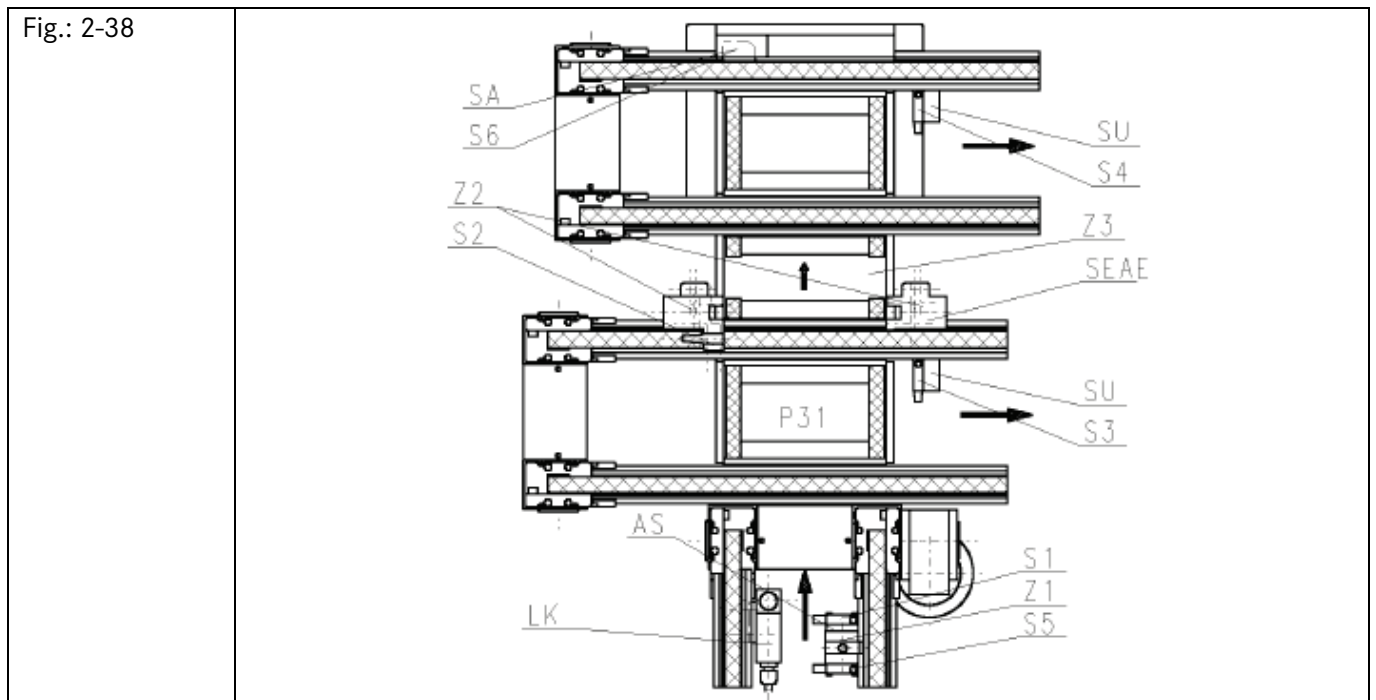
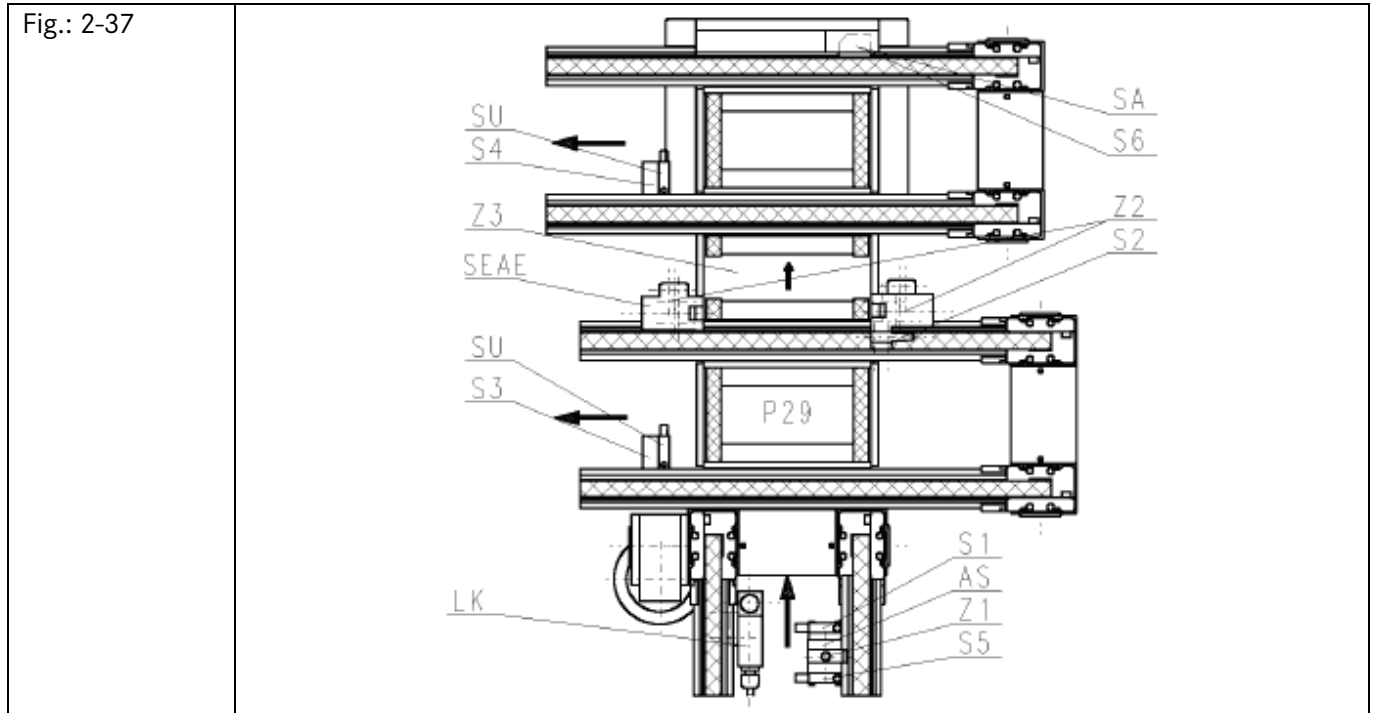

Fig.: 2-36
Flow chart



2.14 P29 - or P31-Accessory – 300 165 001



2.15 P30 - or P32-Accessory – 300 166 001

Fig.: 2-40

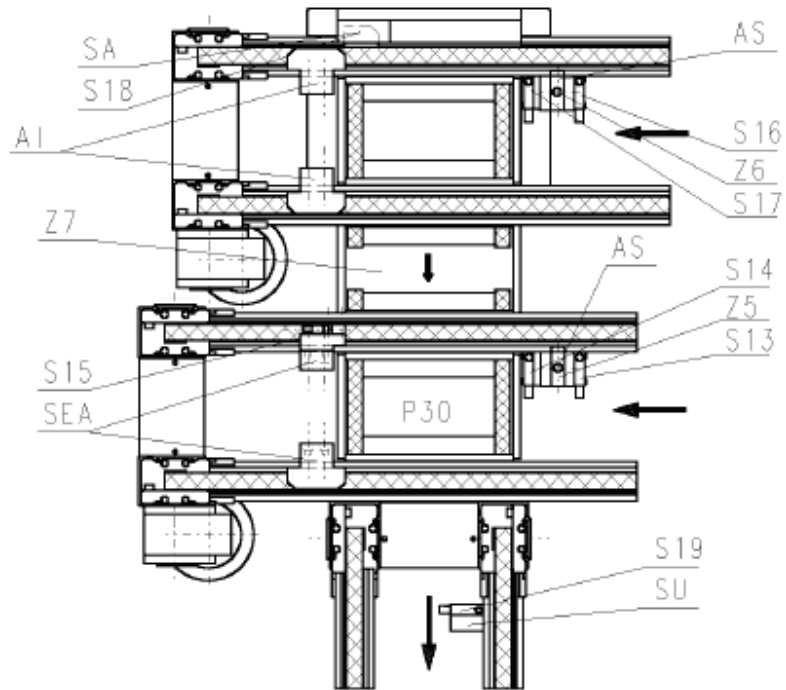

Fig.: 2-41

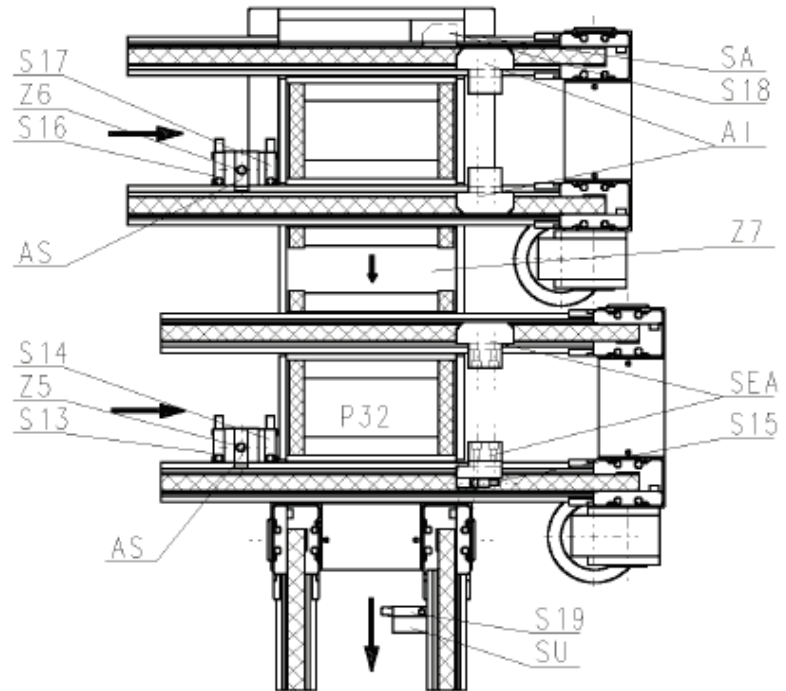
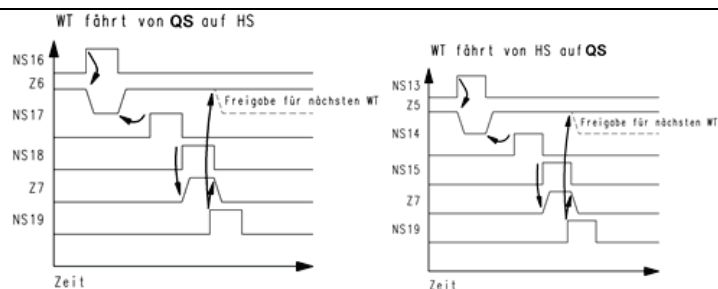

Fig.: 2-42
Flow chart



2.16 P33 - or P35-Accessory – 300 401 001

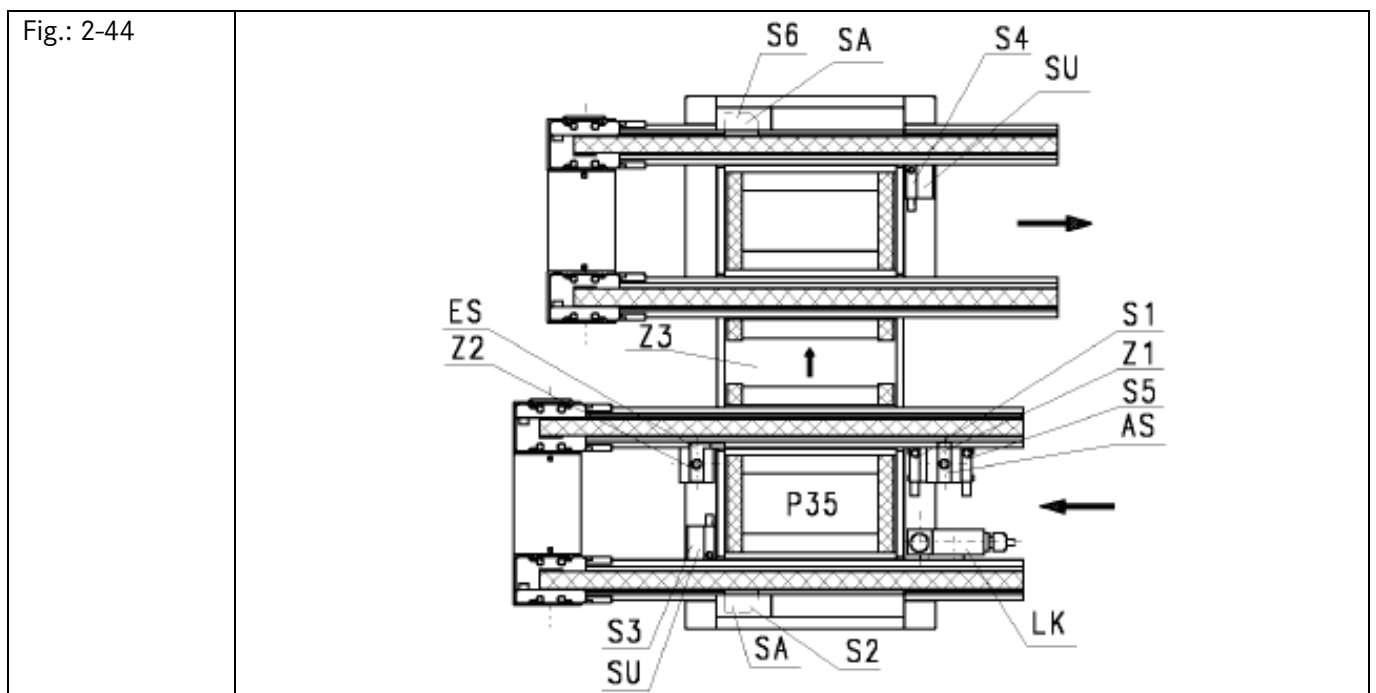
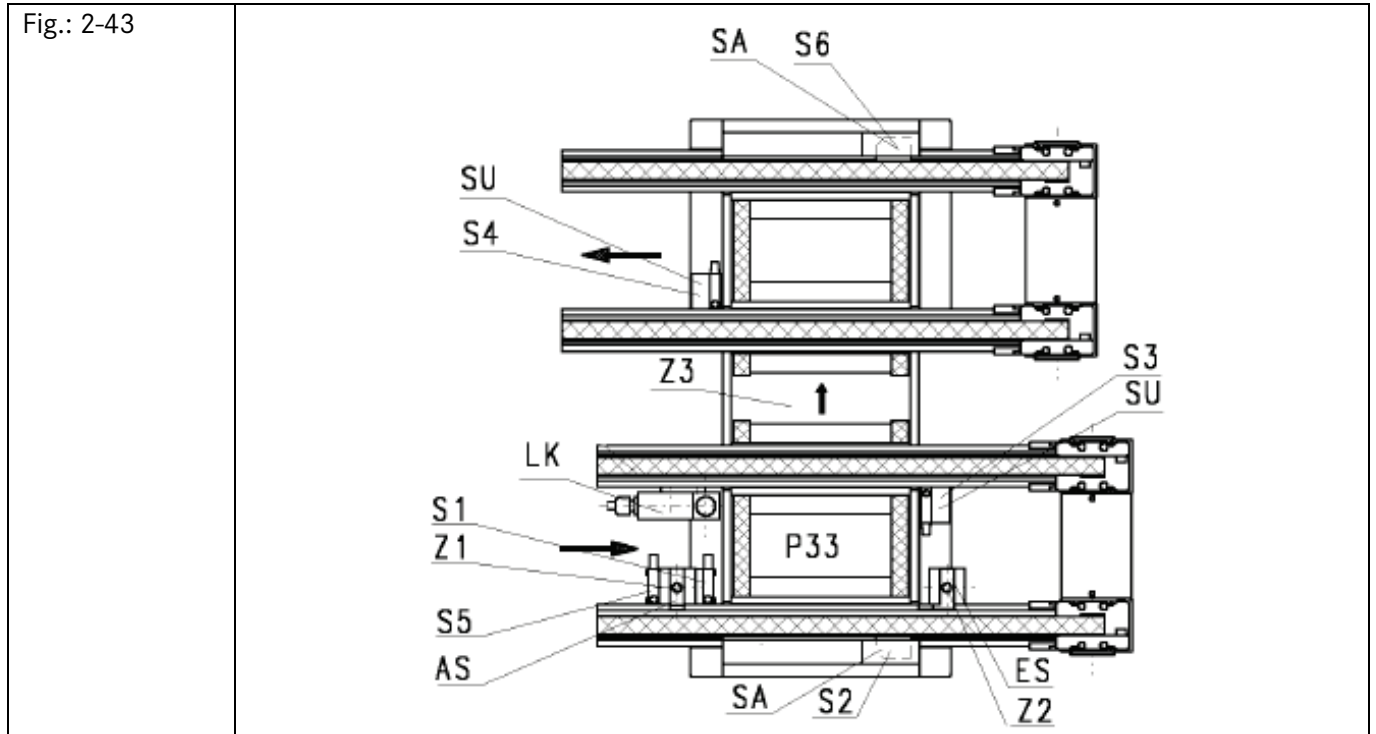

Fig.: 2-45
Flow chart

Flow chart not available, please contact the company STEIN Automation if you are interested.

2.17 P34 - or P36-Accessory – 300 402 001

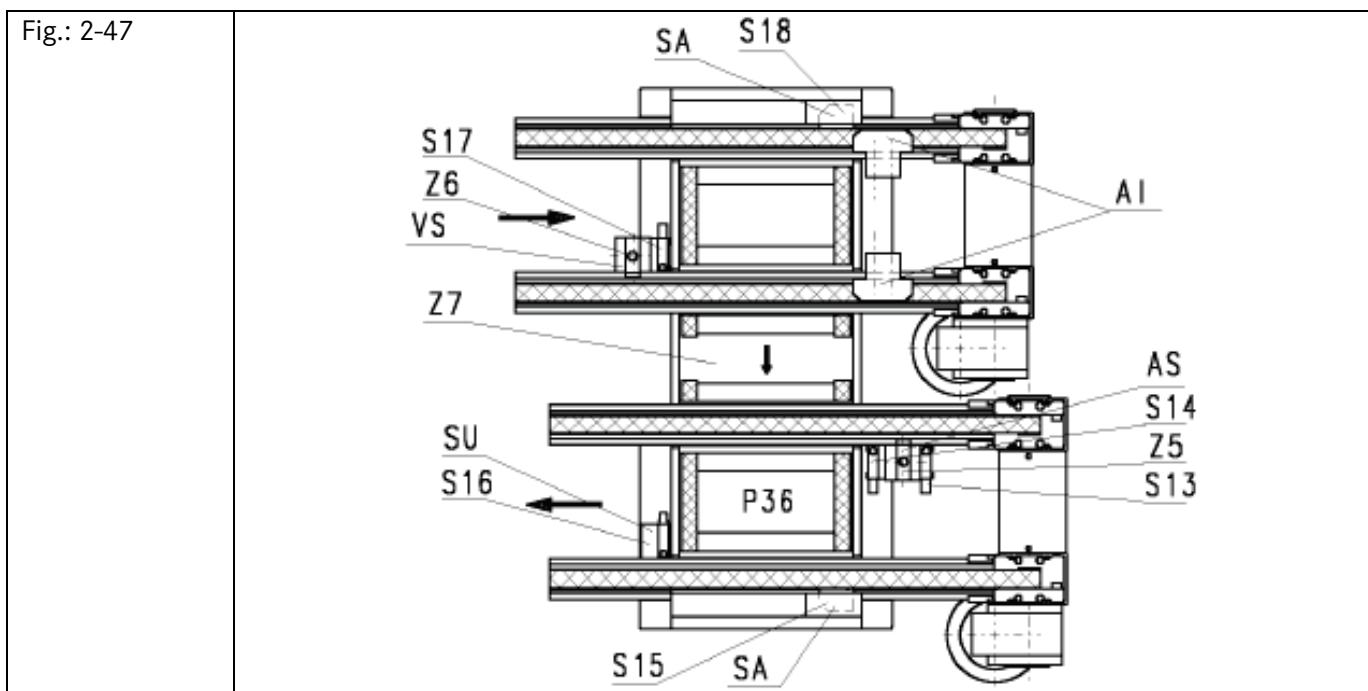
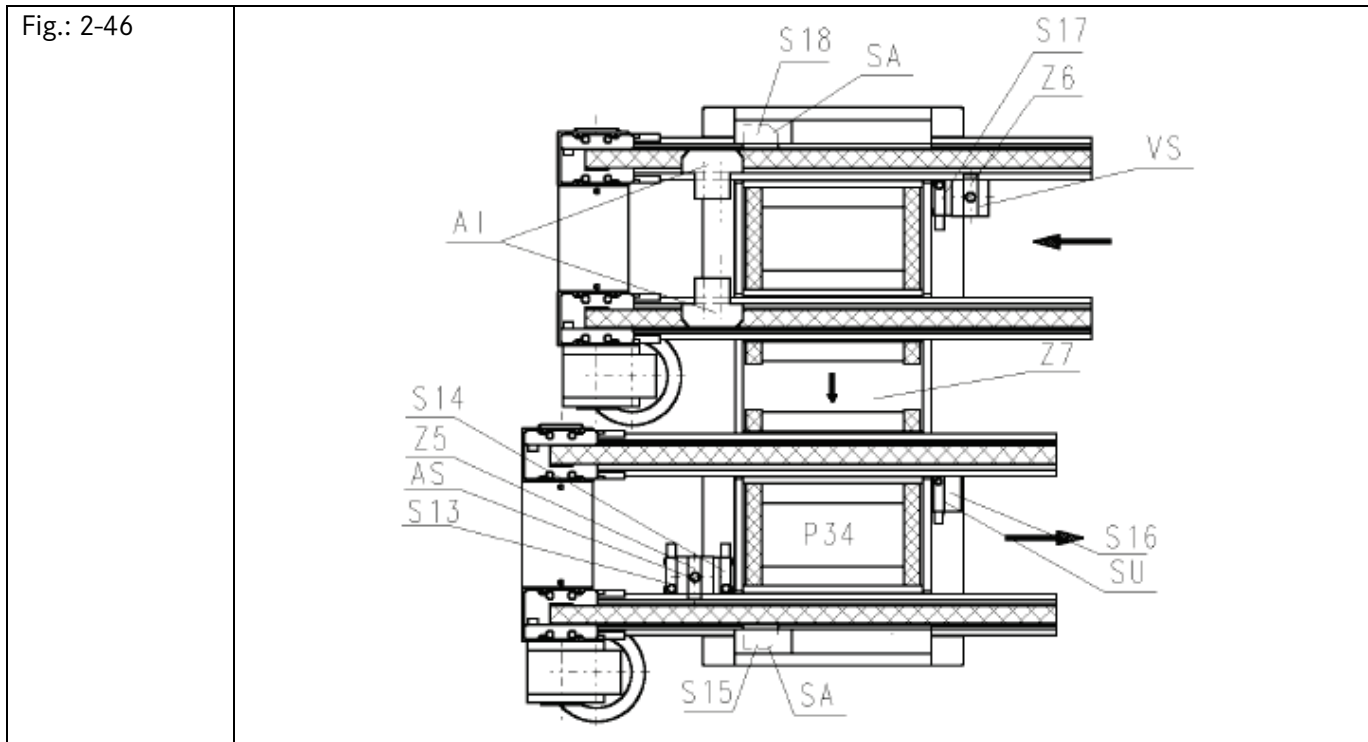
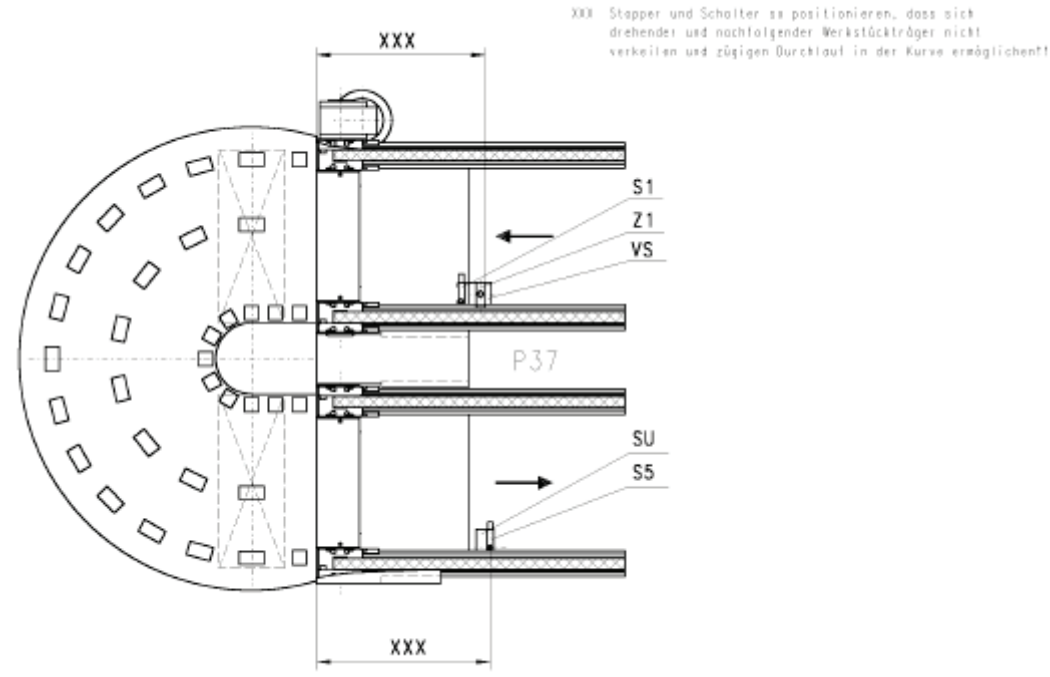
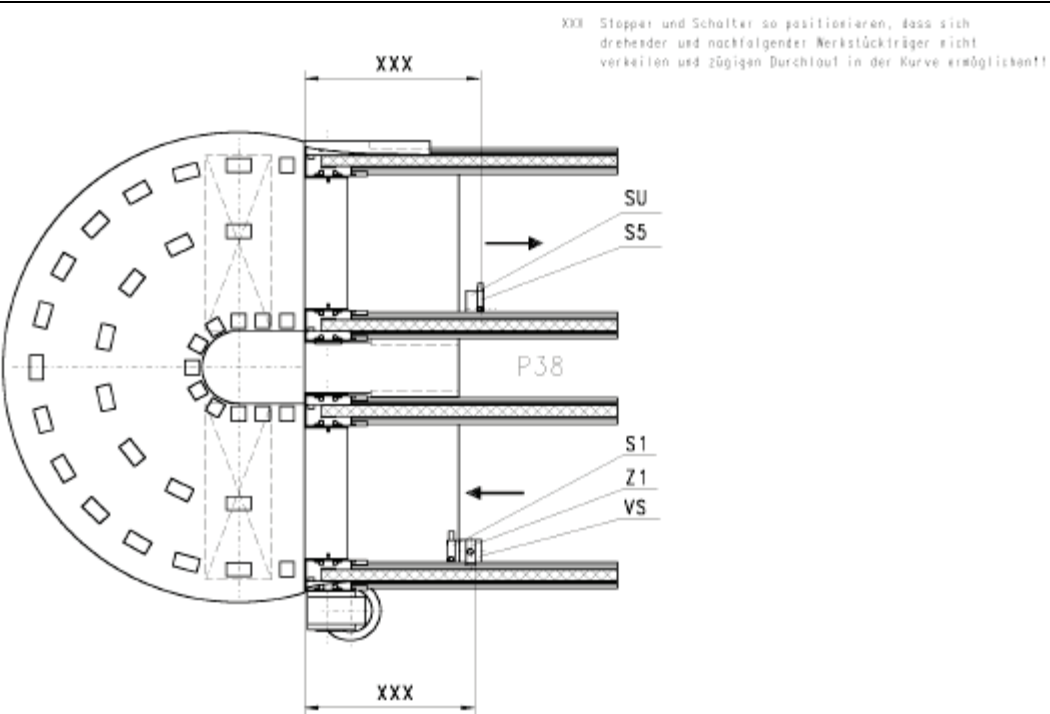

Fig.: 2-48
Flow chart

Flow chart not available, please contact the company STEIN Automation if you are interested

2.18 P37 - or P38-Accessory RB180° – 300 403 001

<p>Fig.: 2-49</p>	 <p>XXX Stopper und Schalter so positionieren, dass sich drehender und nachfolgender Werkstückträger nicht verkeilen und zügigen Durchlauf in der Kurve ermöglichen!</p>
<p>Fig.: 2-50</p>	 <p>XXX Stopper und Schalter so positionieren, dass sich drehender und nachfolgender Werkstückträger nicht verkeilen und zügigen Durchlauf in der Kurve ermöglichen!</p>
<p>Fig.: 2-51 Ablaufdiagramm</p>	<p>Flow chart not available, please contact the company STEIN Automation if you are interested</p>

2.19 P39 - or P40-Accessory RB90° – 300 404 001

Fig.: 2-52

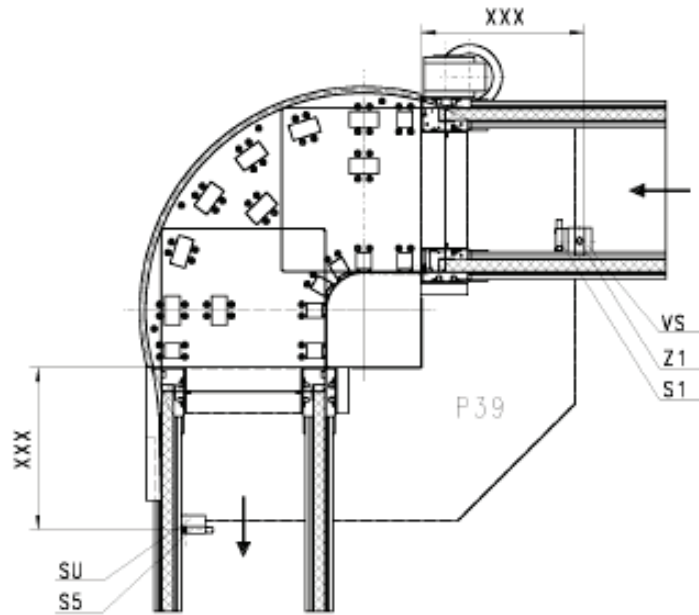

XXX Stopper und Schalter so positionieren, dass sich drehender und nachfolgender Werkstückträger nicht verkeilen und zügigen Durchlauf in der Kurve ermöglichen!

Fig.: 2-53

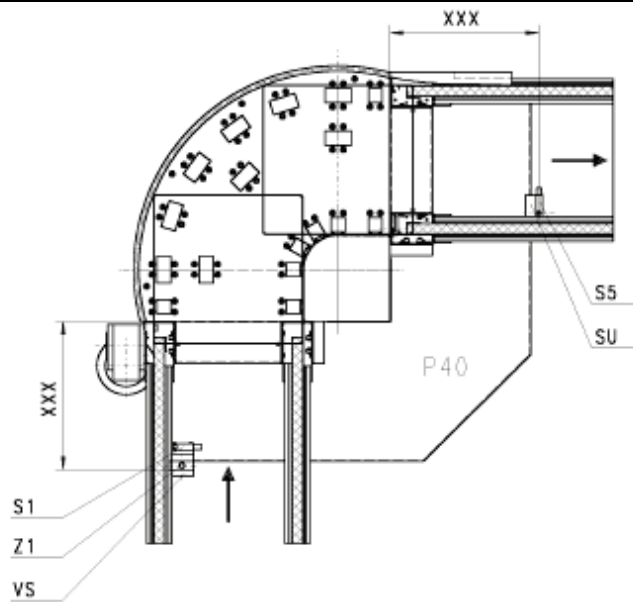

XXX Stopper und Schalter so positionieren, dass sich drehender und nachfolgender Werkstückträger nicht verkeilen und zügigen Durchlauf in der Kurve ermöglichen!

Fig.: 2-54
Ablaufdiagramm

Flow chart not available, please contact the company STEIN Automation if you are interested

2.20 P41 - or P42-Accessory 2xRB90° – 300 405 001

<p>Fig.: 2-55</p>	
<p>Fig.: 2-56</p>	
<p>Fig.: 2-57 Ablaufdiagram</p>	<p>Flow chart not available, please contact the company STEIN Automation if you are interested</p>

2.21 P43 - or P44-Accessory 2xRB180° (Alpha) - 300 406 001

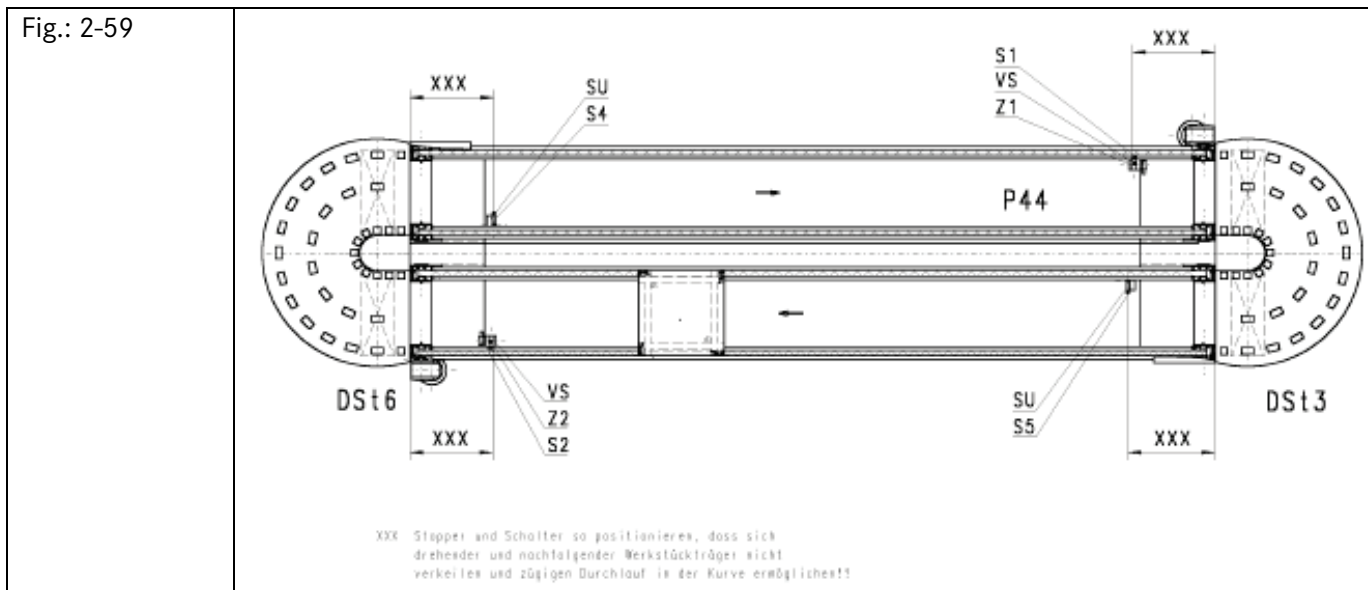
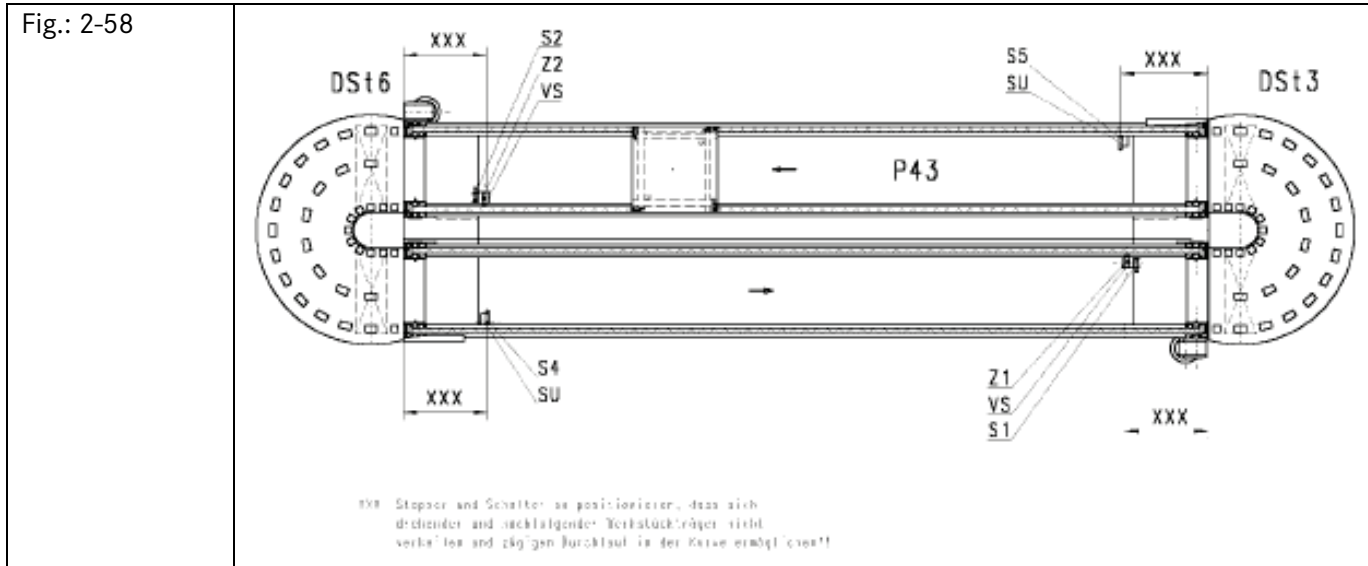



Fig.: 2-60
Ablaufdiagramm

Flow chart not available, please contact the company STEIN Automation if you are interested

3 Installation Declaration

<p>Installation Declaration in accordance with EC Machinery Directive 2006/42/EC, Annex II B.</p>	
--	---

We hereby declare that the incomplete machine

Stop devices, models S, VS, AS, ES, ASA, ASB, ASC
--

satisfy the following fundamental regulations, to the extent possible based on the scope of delivery:

- | | |
|--------------------------|------------|
| • EC Machinery Directive | 2006/42/EC |
| • EC-EMC Directive | 2014/30/EC |

Moreover we declare that the special technical documents for these incomplete machines have been produced in accordance with Annex VII Part B, and that we are obligated to provide these documents via our documentation department at the request of the market supervisory authority.

Commissioning of the incomplete machine is prohibited until the incomplete machine has been integrated in a system or machine, and this system or machine satisfies the provisions of the EC Machinery Directive, and an EC Declaration of Conformity is present (after verification).

Person authorized to compile the technical documentation:

- Stefan Reister, Stein Automation GmbH - Electrical Engineering Department

Language of the original declaration: German

Place / Date:

Villingen-Schwenningen, 04. July 2016

Manufacturer's signature:



Information about the signer:

Jürgen Noailles, Managing Director

Notes

This information reflects the technical status at the time of printing.
STEIN Automation reserves the right to make technical updates.

STEIN Automation GmbH & Co. KG

Carl-Haag-Straße 26
78054 VS-Schwenningen

Telephone +49 (0)7720 / 8307-0
info@stein-automation.de

www.stein-automation.de