

RLE01-HPP

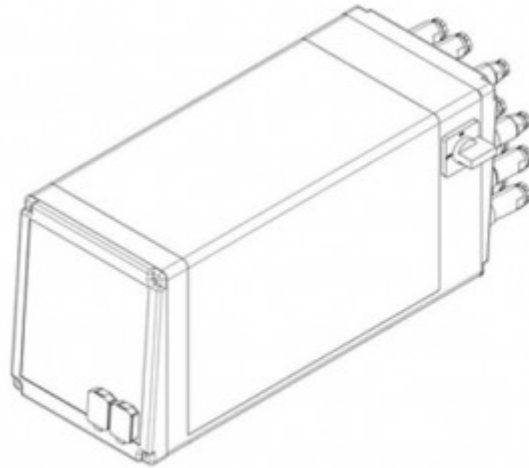

Data sheet RLE01-HPP

Roller Forming Unit

Rivet shank Ø: up to 0 mm | Force: up to 1.50 kN | Stroke: up to 30 mm

Key features | Content of delivery

RLE01-HPP Roller Forming Unit

Forming process: Roller forming

Standard Version

- Nominal force 1.5 kN @ 6 bar (max. operating pressure)
- Spindle stroke 5 - 30 mm with 0.01 mm micrometer scale and mechanical stroke limit
- Application specific motor (typically: gear motor with brake)
- Spindle rotational speed typically approx. 500/min. (optimal speed will be determined via trials)
- Machine weight: approx. 30 kg (excl. roll forming head)
- Electro-pneumatic drive - power supply @x@V, @Hz
- Permanently lubricated spindle
- Adapter for roll forming head
- Color: light grey RAL 7035

Including

- HPP-010-181, Process-Control HPP-25 for 151, connections X1, X2, X3, X20, X21
- Incl. SEI-100-181, Distance sensor, Type HPP-25
- Incl. SEI-200-151, Pressure sensor, Type HPP-25
- HPP-X4-02, Connection X4 for emergency-stop, w/out two-hand relay
- HPP-X6-01, Connection X6, external safety / reset
- HPP-X9-01, Connection X9, PLC interface with cable, 5m
- HPP-045-03, Sensor cable extension 3 meter - Total length 4 meter
- SEI-OTH-181, Sensor upper spindle home position (TDC)
- PNP-HPP-151, Pneumatic service unit and pneumatic control package for HPP
- Standard accessories and user manual in the language of destination

Options

- HPP-X5-01, Connection X5 PVM Module (for control of PNP-PRV-020)
- PNP-PRV-020, Proportional-pressure control, integrated & ready for operation (requires HPP-X5-01)
- HPP-DLL-S7L-x, HPP-25 - Siemens S7 Communication link (S7LINK). License code to be ordered for each HPP control
- HPP-DLL-PCT, PC-Analysis Software HPP-PCTool, incl. UDP Protocol (on USB Stick)

- Roll forming head

(Roller forming units incl. roll forming head is only offered after a prior feasibility analysis)

In case customer will provide roll forming head, we must receive following information:

- Desired rotational spindle (roll forming head) speed
- Operation with frequency converter yes/no
- Dimensions (drawing) of roll forming head with details of weight, height, diameter and number of rollers

Subject to change.

Drawing

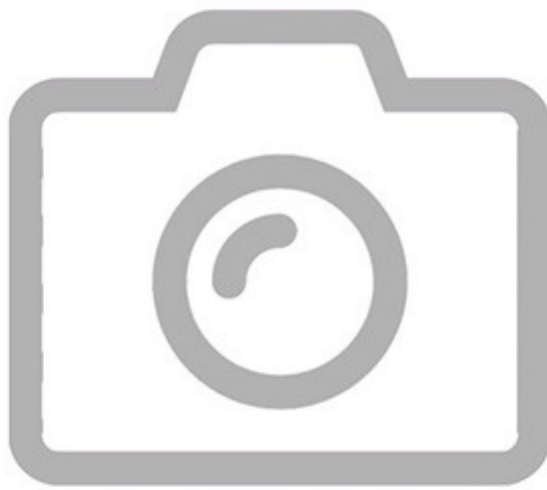

Forming tool lengths

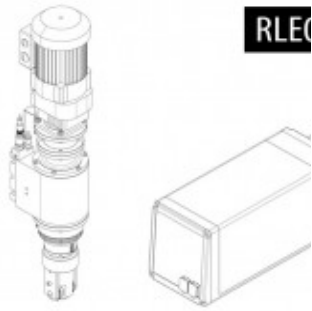

Radius mm Rp	Tool length mm Ls	Free height mm H	Shank Ø mm Ds	Angle of inclination α
{radius}	{length}	{height}	{shaft}	{angle}



Our engineers are routinely meeting the demands of complex design problems. Having the specific tools needed for your metal forming project can mean the difference between success and failure. Contact us with your unique application for custom tooling.

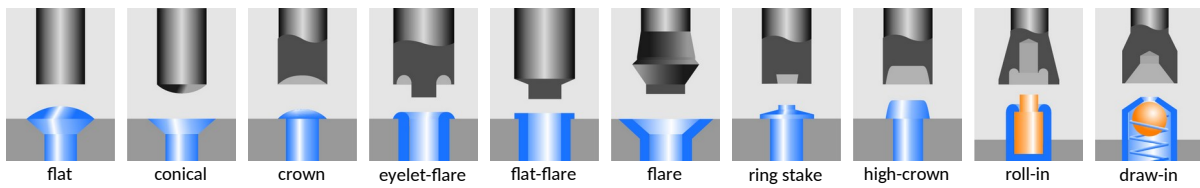

Industries & Applications



BalTec AG
Switzerland / Germany

BalTec (UK) Ltd.
United Kingdom

BalTec France
France

BalTec Corporation
USA / Canada / Mexico

BalTec do Brasil
Brazil

BalTec Machinery (Shanghai) Ltd.
China

BalTec Italia Srl
Italia

BalTec