

RNR 281R
RC-30

Data sheet RNR281R-RC3

Rotary Indexing Table Riveting Machine

Rivet shank Ø: up to 7 mm | Force: up to 9.50 kN | Stroke: up to 40 mm

Key features | Content of delivery

RNR281R-RC3 Rotary Indexing Table Riveting Machine

Forming process: Radial

Rotary indexing riveting machine with rotary indexing table TC White

- with RNR281R and RC-30 time based control
- Supply voltage 3x230-280V, 50/60Hz or 3x400/480V, 50/60Hz (other supply voltages on request)
- rivet mushroom & pressure shell Rp=65 mm / Ls=39 mm (other Rp/Ls on request)
- Color: Light grey RAL 7035

Subject to change.

Drawing

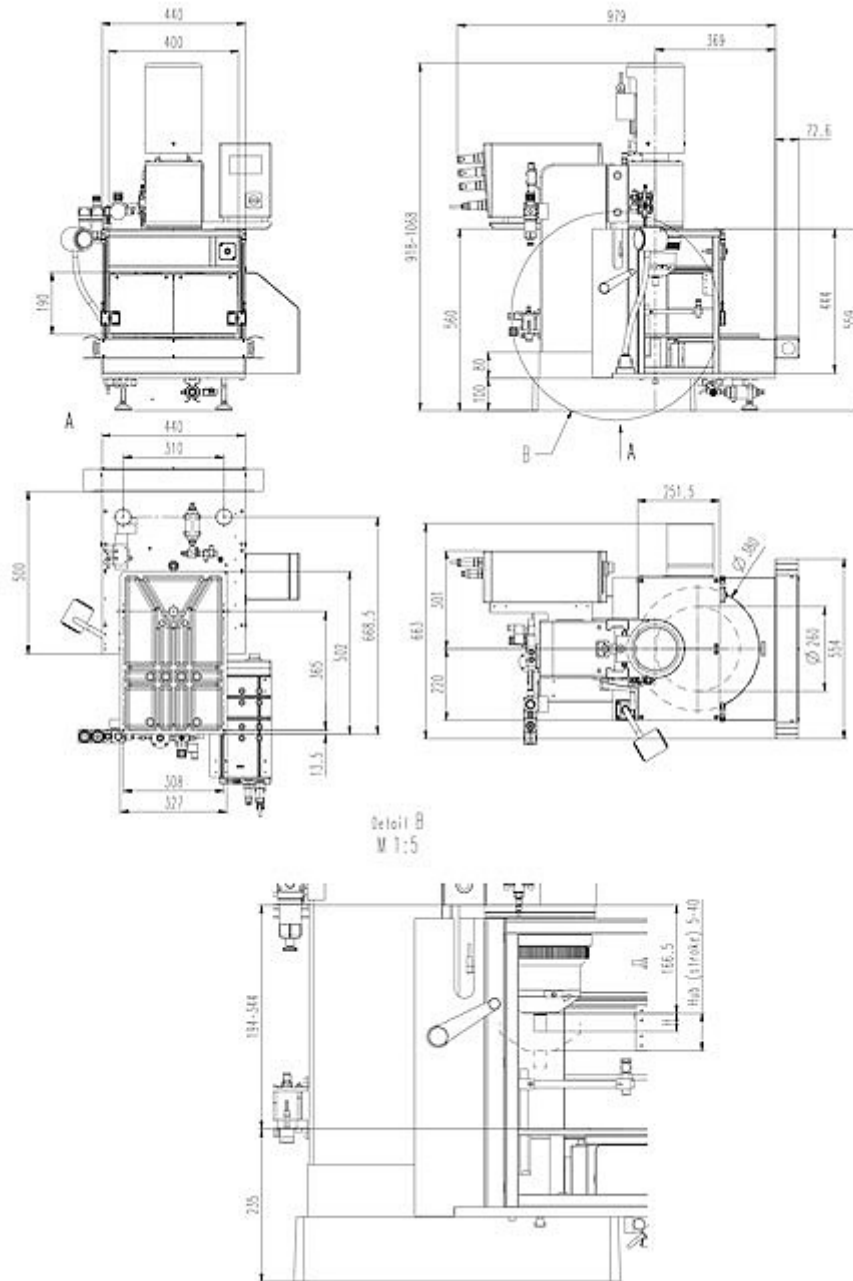

Forming tool lengths



Radius mm Rp	Tool length mm Ls	Free height mm H	Shank Ø mm Ds	Angle of inclination α
100.00	68.00	28.00	10	5° 37'
116.00	84.00	44.00	10	4° 47'
132.00	100.00	60.00	10	4° 10'
148.00	116.00	76.00	10	3° 41'
170.00	135.00	98.00	10	3° 10'
191.00	159.00	119.00	10	2° 49'
240.00	208.00	168.00	10	2° 13'

Forming tool profile



Our engineers are routinely meeting the demands of complex design problems. Having the specific tools needed for your metal forming project can mean the difference between success and failure. Contact us with your unique application for custom tooling.

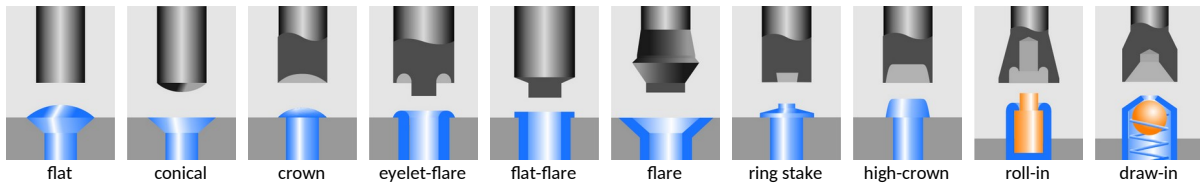

Industries & Applications



BalTec AG
Switzerland / Germany

BalTec (UK) Ltd.
United Kingdom

BalTec France
France

BalTec Corporation
USA / Canada / Mexico

BalTec do Brasil
Brazil

BalTec Machinery (Shanghai) Ltd.
China

BalTec Italia Srl
Italia

BalTec