

RNR 181  
RC-30

## Data sheet RNR181-RC3

Rotary Indexing Table Riveting Machine

Rivet shank Ø: up to 6 mm | Force: up to 6.60 kN | Stroke: up to 30 mm

## Key features | Content of delivery

### RNR181-RC3 Rotary Indexing Table Riveting Machine

#### Forming process: Radial

Rotary indexing riveting machine with rotary indexing table TC White

- with RNR181 and RC-30 time based control
- Supply voltage 3x230-280V, 50/60Hz or 3x400/480V, 50/60Hz (other supply voltages on request)
- rivet mushroom & pressure shell Rp=65 mm / Ls=39 mm (other Rp/Ls on request)
- Color: Light grey RAL 7035

Subject to change.

## Drawing

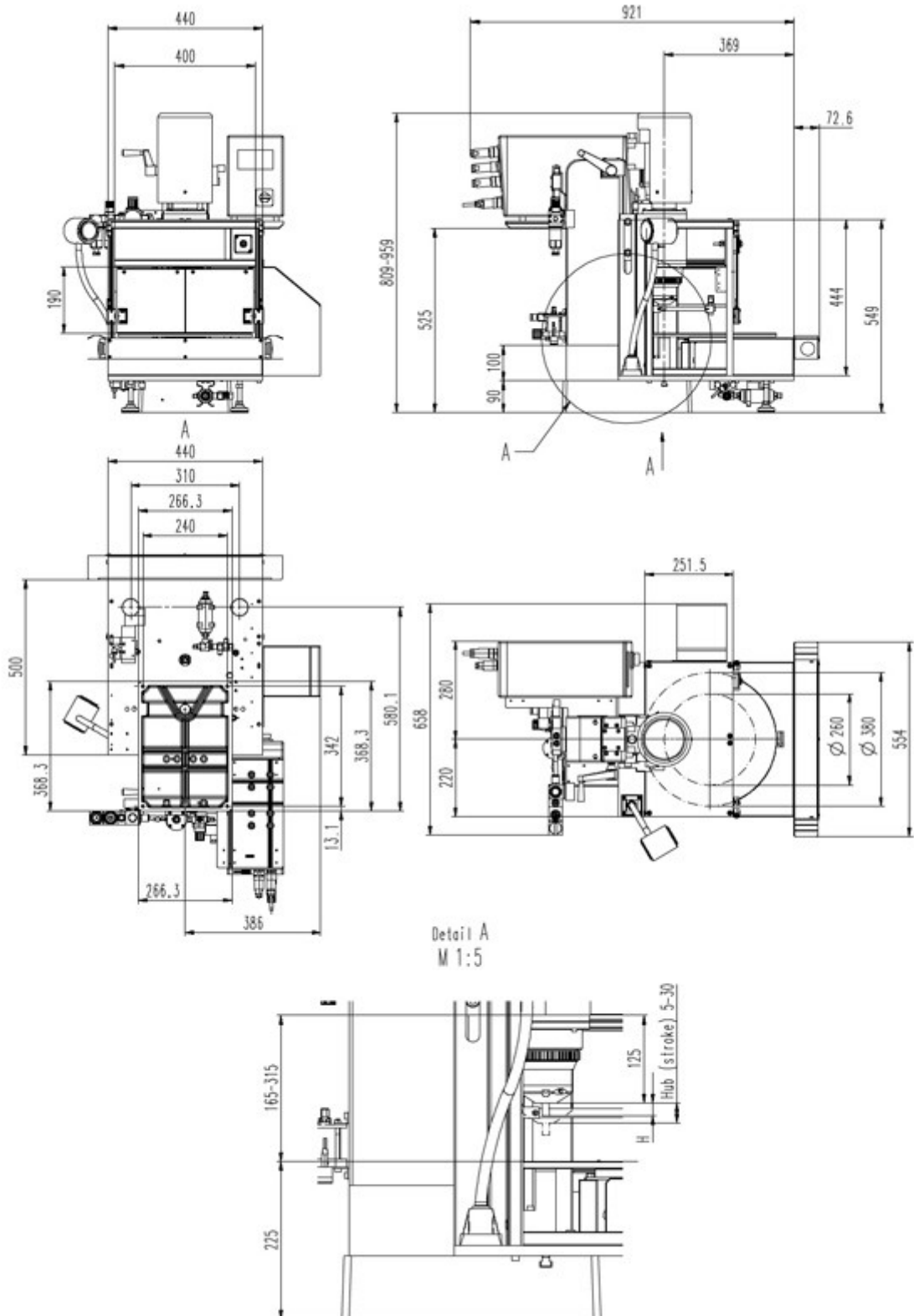

## Forming tool lengths

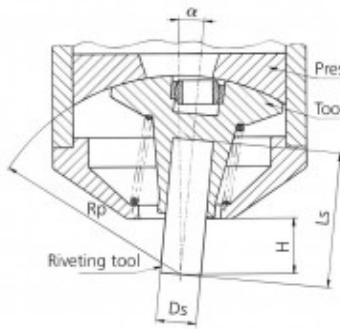

Radius mm Rp	Tool length mm Ls	Free height mm H	Shank Ø mm Ds	Angle of inclination α
65.00	39.00	18.00	10	6° 02'
80.00	54.00	33.00	10	4° 47'
100.00	74.00	53.00	10	3° 44'
120.00	94.00	73.00	10	3° 04'
132.00	106.00	85.00	10	2° 46'

## Forming tool profile



Our engineers are routinely meeting the demands of complex design problems. Having the specific tools needed for your metal forming project can mean the difference between success and failure. Contact us with your unique application for custom tooling.

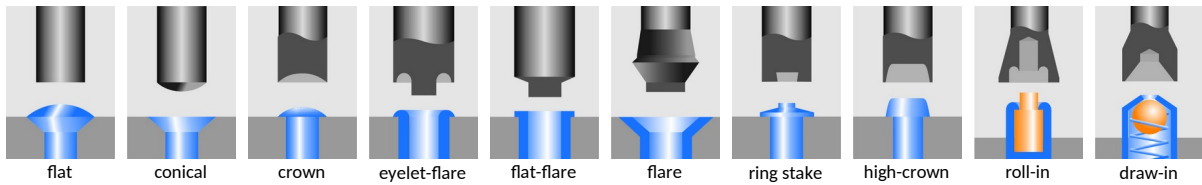

## Industries & Applications



**BalTec AG**  
Switzerland / Germany

BalTec (UK) Ltd.  
United Kingdom

BalTec France  
France

BalTec Corporation  
USA / Canada / Mexico

BalTec do Brasil  
Brazil

BalTec Machinery (Shanghai) Ltd.  
China

BalTec Italia Srl  
Italia

# BalTec