

RND 231
RC-30

Data sheet RND231-RC3

Double Riveting Machine

Rivet shank Ø: up to 8 mm | Force: up to 12.00 kN | Stroke: up to 40 mm

Key features | Content of delivery

RND231-RC3 Double Riveting Machine

Forming process: Radial

Standard Version

- Complete work station
- Two identical RNE 231 riveting units (both riveting units cycle simultaneously)
- Frame to which riveting units are mounted. Distance between riveting heads adjustable
- With riveting units 181 - 231, frame ready to be placed on a work table
- Nominal force 12 kN @ 6 bar (max. operating pressure)
- Rivet shaft up to Ø 8.5 mm (Steel 370 N/mm²)
- Spindle stroke 5 - 40 mm with 0.01mm micrometer scale and mechanical stroke limit
- Machine weight: approx. 150 kg (Additional weight of the machine table is 100 kg)
- Electro-pneumatic drive - power supply @x@V, @Hz
- Permanently lubricated spindle
- Pressure cup & tool holder Rp=@mm for forming tool length Ls=@mm
- Color: light grey RAL 7035

Including

- RC3-010, RC-30 Time Based Control, connections X1, X2, X3, X20, X21, X22. One unit to control both riveting units
- RC3-X4-01, Connection X4, incl. two-hand relays, for Emergency-Stop and two-hand control
- NSL-2HD-010, two-hand control via push button, w/out emergency-stop
- PNP-010-231, Pneumatic service unit, lubrication and control package for RC-30. One unit to control both riveting units
- NZ-201, one adjustable task light, 24 VDC, LED
- Manual grease press (is not supplied with automatic spindle lubrication system)
- Standard accessories and user manual in the language of destination

Options

- RND-050, customized (per application) safety enclosure for CE compliance
- RC3-X5-01, Connection X5, incl. PVM Module
- RC3-X6-01, Connection X6, external safety / Reset
- NZ-039, Automatic spindle lubrication system with lubricant level monitor. One unit to service both riveting units
- NSL-2HD-011, Emergency-Stop (push button) for two-hand control

Subject to change.

Drawing

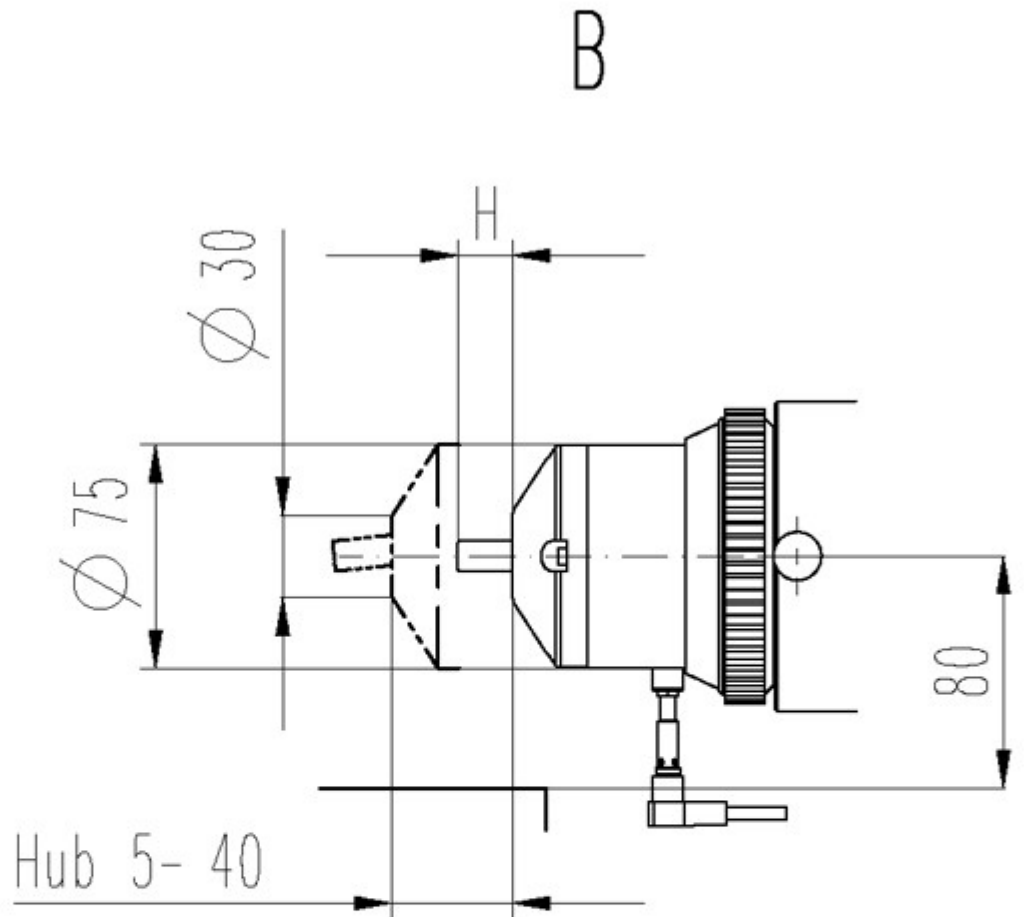

18

Forming tool lengths

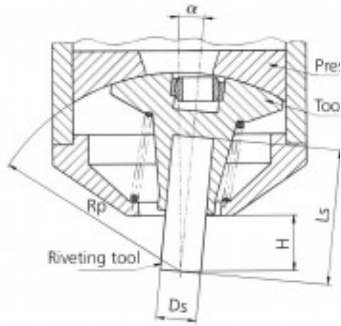

Radius mm Rp	Tool length mm Ls	Free height mm H	Shank Ø mm Ds	Angle of inclination α
65.00	39.00	18.00	10	6° 02'
80.00	54.00	33.00	10	4° 47'
100.00	74.00	53.00	10	3° 44'
120.00	94.00	73.00	10	3° 04'
132.00	106.00	85.00	10	2° 46'

Forming tool profile



Our engineers are routinely meeting the demands of complex design problems. Having the specific tools needed for your metal forming project can mean the difference between success and failure. Contact us with your unique application for custom tooling.

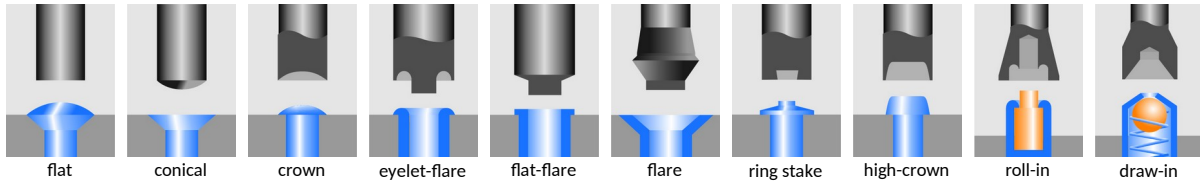

Industries & Applications



BalTec AG
Switzerland / Germany

BalTec (UK) Ltd.
United Kingdom

BalTec France
France

BalTec Corporation
USA / Canada / Mexico

BalTec do Brasil
Brazil

BalTec Machinery (Shanghai) Ltd.
China

BalTec Italia Srl
Italia

BalTec