

RNS 381
RC-30

Data sheet RNS381-RC3

Pedestal Riveting Machine

Rivet shank Ø: up to 20 mm | Force: up to 40.00 kN | Stroke: up to 50 mm

Key features | Content of delivery

RNS381-RC3 Pedestal Riveting Machine

Forming process: Radial

Standard Version

- Nominal force 40 kN @ 65 bar (max. operating pressure)
- Rivet shaft up to Ø 20 mm (Steel 370 N/mm²)
- Spindle stroke 5 - 50 mm with 0.01mm micrometer scale and mechanical stroke limit
- Machine weight: approx. 500 kg
- Hydraulic pack weight (empty): approx. 54kg
- Electro-pneumatic drive - power supply @x@V, @cps
- Permanently lubricated spindle
- Pressure cup & tool holder Rp=@ mm for forming tool length Ls=@ mm
- 852725, Floor standing column, incl. table with height adjustment
- Color: light grey RAL 7035

Inclusive

- RC3-010, RC-30 Time Based Control, connections X1, X2, X3, X20, X21
- RC3-X4-02, Connection for Emergency-Stop (does not include push button)
- PNH-010-381, Hydraulic power unit, with oil, pressure regulation on the valve manifold
- NZ-201, Adjustable task light, 24 VDC, LED
- Manual grease press (not included with automatic lubrication)
- Standard accessories and user manual in the language of destination
- **Cycle initiation device (push button or foot switch) not included**

Options

- RNS-SE-010, Left / right safety panels, open in the front, NSL-2HD-010 mechanical 2 hand buttons without E-stop, 2 hand relay (for 2 hand button & E-stop), RC3-X4-01 connection
- RNS-SE-020, Left side fixed panel / right side door w/ safety interlock, light curtain, NSL-010 foot switch, RC3-X4-02 connection
- RNS-SE-030, Left & right side door w/ safety interlock, light curtain, NSL-010 foot switch, RC3-X4-02 connection

Additional options

- RC3-X5-01, Connection X5 PVM Module (for control of PNP-PRV-020)
- PNP-PRV-020, Proportional-pressure control, integrated & ready for operation (requires RC3-X5-01)
- HPP-X6-01, Connection X6, external safety / Reset
- SEI-UTE-000, Sensor for spindle in work position
- SEI-OTH-381, Sensor upper spindle position (TDC)
- NSL-010, foot switch
- NHE-MYC-U-01, Workpiece detection device NHE-U
- NHE-MST-xxx, NHE probe arm and probe (@)
- NZ-039, Automatic spindle lubrication system with lubricant level monitor
- NSL-2HD-011, Emergency-Stop (push button) for two-hand control (for option RNS-SE-010 only)

Subject to change.

Drawing

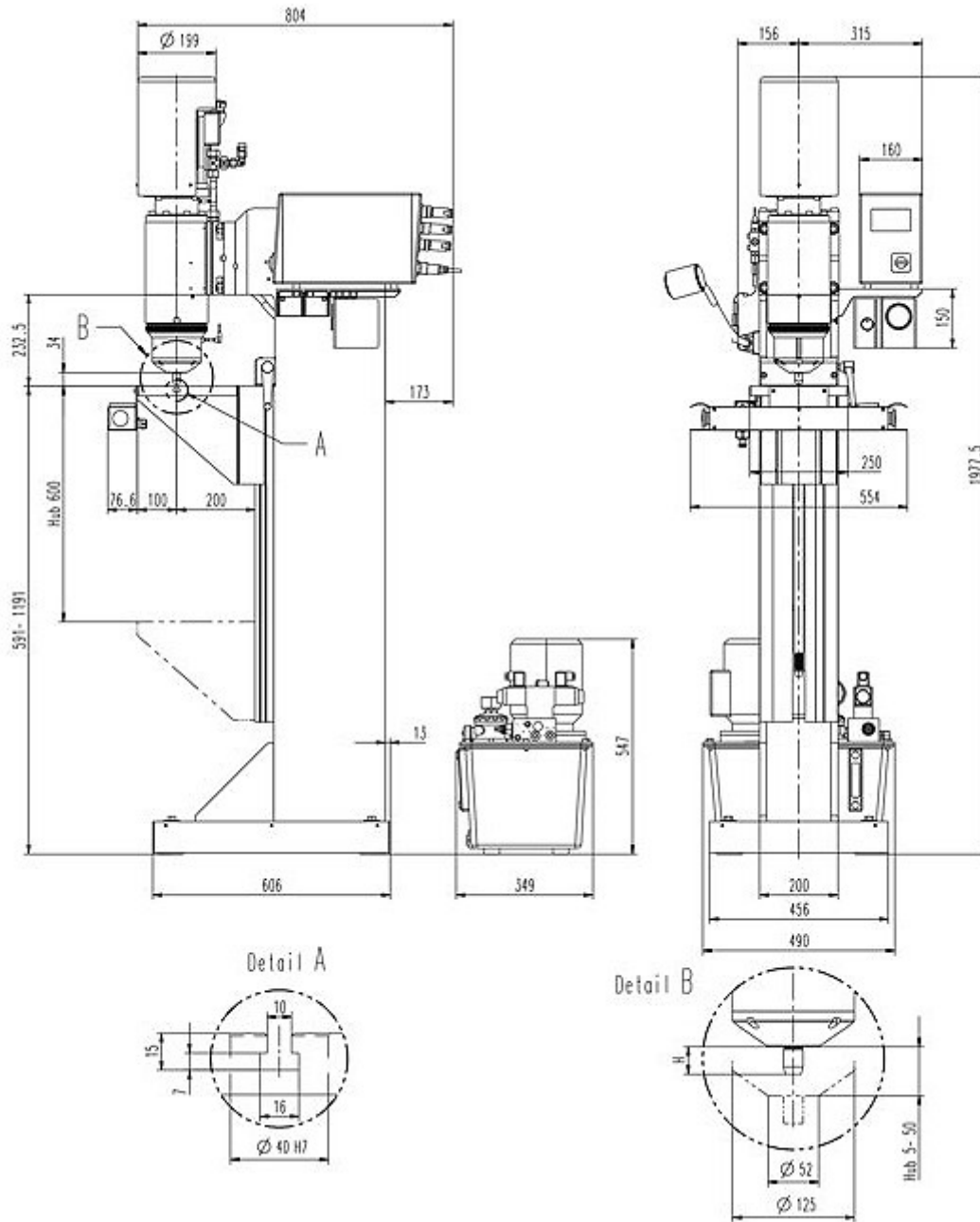

Forming tool lengths

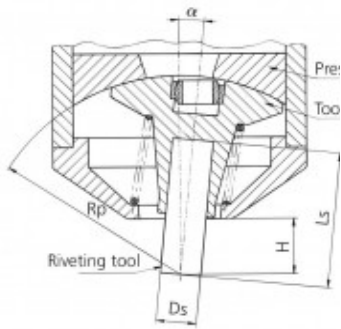

Radius mm Rp	Tool length mm Ls	Free height mm H	Shank Ø mm Ds	Angle of inclination α
100.00	68.00	28.00	10	5° 37'
116.00	84.00	44.00	10	4° 47'
132.00	100.00	60.00	10	4° 10'
148.00	116.00	76.00	10	3° 41'
170.00	135.00	98.00	10	3° 10'
191.00	159.00	119.00	10	2° 49'
240.00	208.00	168.00	10	2° 13'

Forming tool profile



Our engineers are routinely meeting the demands of complex design problems. Having the specific tools needed for your metal forming project can mean the difference between success and failure. Contact us with your unique application for custom tooling.

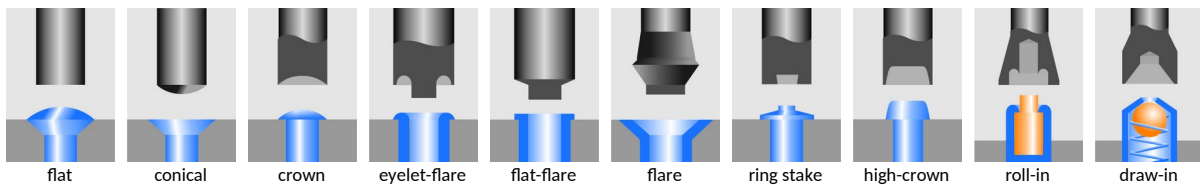

Industries & Applications



BalTec AG
Switzerland / Germany

BalTec (UK) Ltd.
United Kingdom

BalTec France
France

BalTec Corporation
USA / Canada / Mexico

BalTec do Brasil
Brazil

BalTec Machinery (Shanghai) Ltd.
China

BalTec Italia Srl
Italia

BalTec